



MEDIA MATIC 50

Instruction manual



Before using the machine please carefully read the instructions

Index

Chapter 1. • Foreword	
1.1. Introduction.....	1-1
1.2. Performances of packaging machine.....	1-1
1.3. Machine identification.....	1-1
1.4. Weight and dimensions of packed machine	1-3
1.5. Machine weight and dimensions.....	1-3
Chapter 2. Machine installation	
2.1. Transport and positioning.....	2-1
2.2. Environmental conditions.....	2-3
2.3. Electrical connections.....	2-5
Chapter 3. Machine adjustment and setting up	
3.1. Adjustment.....	3-1
3.2. Manual and automatic cycle.....	3-9
3.3. Film roll insertion	3-11
3.4. Belt adjustment.....	3-13
3.5. Air flow adjustment.....	3-15
3.6. Film roll support and packaging plate adjustment	3-17
3.7. Execution of 1 st film sealing.....	3-17
3.8. Film coupler on wrapping machine.....	3-19
3.9. Introducing the object to be wrapped.....	3-21
3.10. Packaging.....	3-21
Chapter 4. Limits and conditions in the use of machine	
4.1. Max. packing sizes.....	4-1
4.2. Items not packed.....	4-1
Chapter 5. Film features	
5.1. Films to be used.....	5-1
5.2. Band A calculation.....	5-1
Chapter 6. Safety standards	
6.1 Warnings.....	6-1
Chapter 7. Ordinary maintenance	
7.1. Precautions for ordinary maintenance interventions	7-1
7.2. Sealing blade cleaning.....	7-1
7.3. Plastic film removal.....	7-3
7.4. Control of cooling liquid.....	7-3
7.5. Rubber and teflon replacement.....	7-5
7.6. Adjustment of the cams.....	7-7
7.7. Changing the sealing wire.....	7-9
7.8. Wiring diagram.....	7-11
7.9. Key wiring diagram.....	7-13
7.10. Spare parts.....	7-15
Chapter 8. Guarantee	
9.1. EC declaration of conformity.....	9-1

Chapter 1. Foreword

1.1. Introduction

You have bought a machine with outstanding features and performance and we thank you very much for your confidence in choosing it. The MINIPACK System is unique in its own kind and has achieved worldwide success with more than 50000 units operating in the of packaging and wrapping field It is handy, low-priced and protected by patents at home and abroad. The technological concept underlining its design, as well as the components and materials used in the manufacturing and testing process are the best assurance of proper operation and long-lasting liability.

1.2. Performances of packaging machine

“MEDIA MATIC 50” is an L-sealer packaging machine equipped with shrinking tunnel. Which represents a real novelty ab it is incorporate in machine structure. Such a tunnel is height and speed adjustable, equipped with temperature adjustment; the machine is more compact and versatile as it is included in its bodywork. This machine can pack up to 900 pieces per hour.

1.3. Machine identification

In every communication with the Manufacturer, always mention the model and the serial number specified on the plate on machine rear.



Chapter 1. Foreword

1.4. Weight and dimensions of packed machine

a = mm 800
b = mm 2780
c = mm 1400
Peso = Kg 287

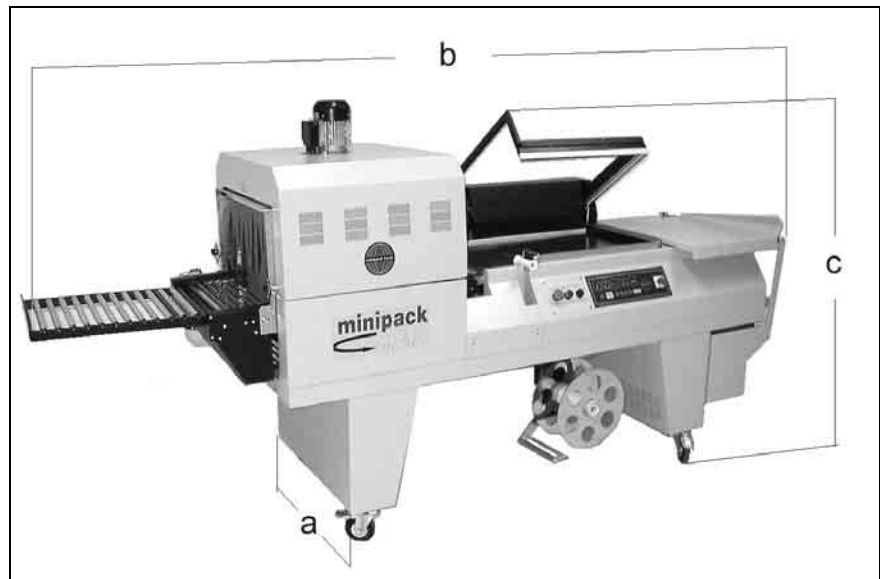

a = mm 900
b = mm 2500
c = mm 1500
Peso = Kg 343

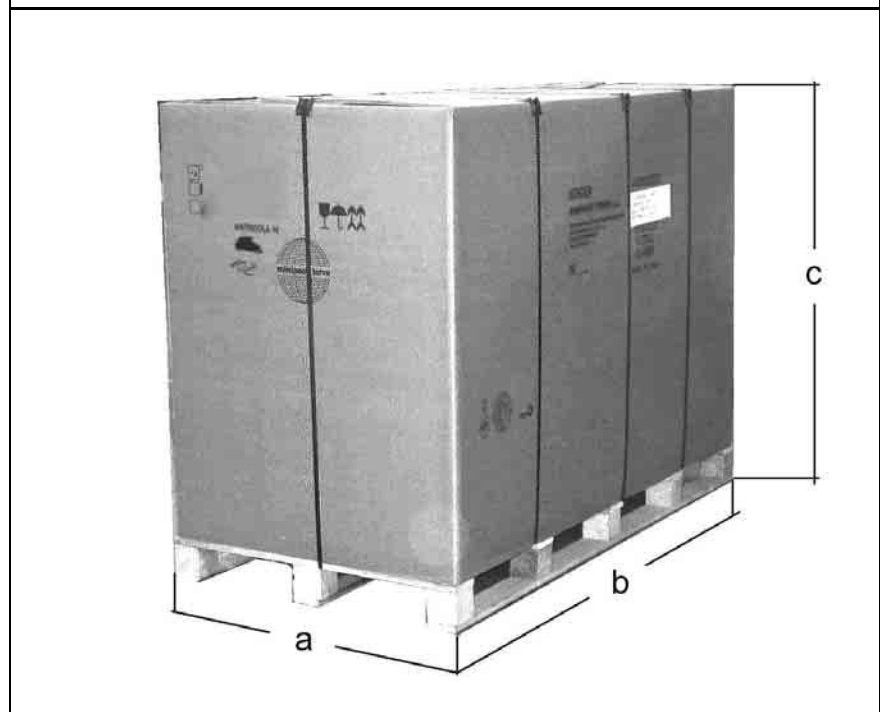

1.5. Machine weight and dimensions

Chapter2. Machine installation

2.1. Transport and positioning

*Cut strap with scissors and remove the cardboard.
Remove the cardboard containing the trolley (Y).
Unscrew the 4 fastening screws of the pallet.
Lift the machine by using a fork lift.
Place the four wheels onto the machine.
Remove the box (X) containing the closing panels and fix them to the legs.*

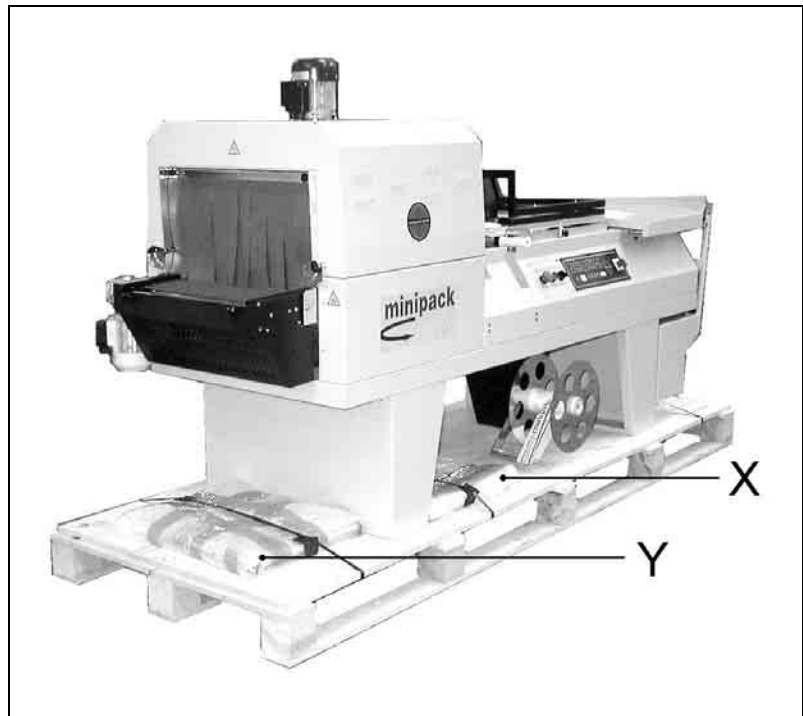

Position the roller plate, coupling it to the conveyor belt.

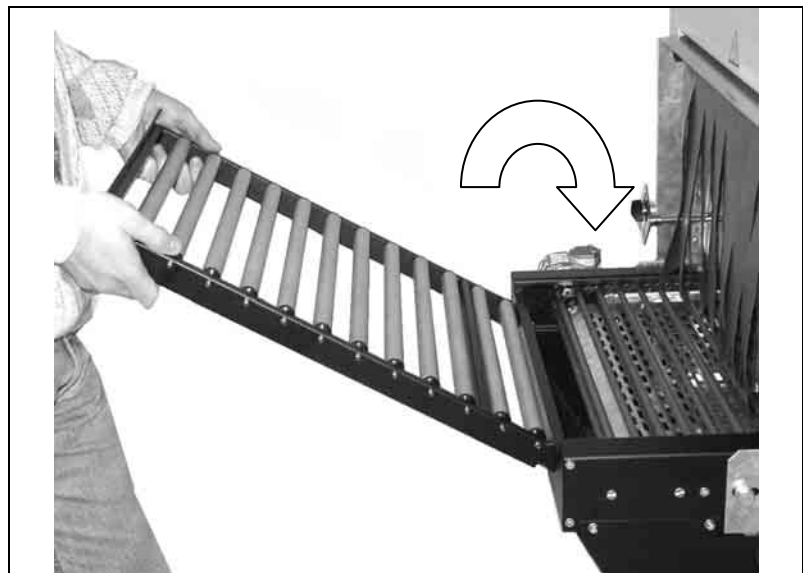

2.2. Environmental conditions

Place the machine in a suitable environment free from humidity, gases, explosives, combustible materials.

Working environmental conditions:

- *Temperature from + 5°C to + 40°C*
- *Relative humidity from 30% to 90%, without condensation*

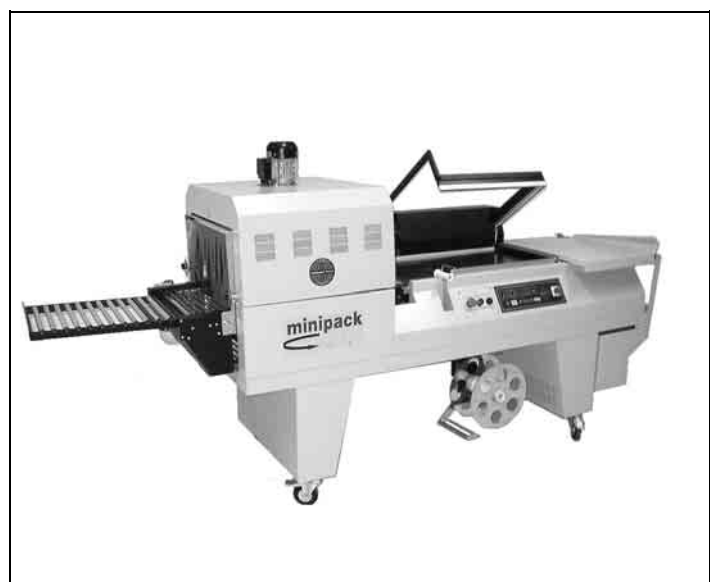

Machine safety factor = IP32

The aerial noise made by the machine is lower than 70 dB

2.3. Electrical connections

OBSERVE HEALTH AND SAFETY REGULATIONS!

GROUNDING OF THE UNIT IS OBLIGATORY!

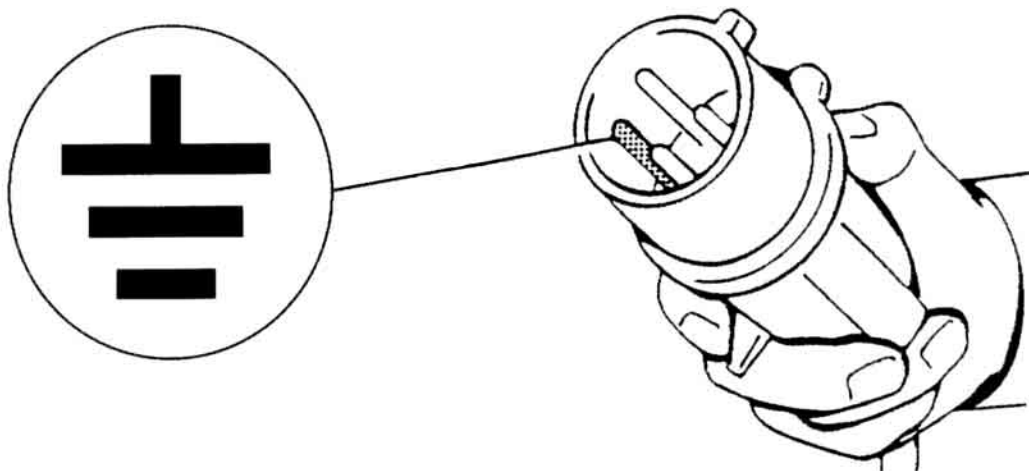

Before executing electrical connections, make sure the mains voltage matches the one on the plate on machine rear and that the earthing contact complies with the safety rules in force. In case of doubts about the mains voltage, contact the local public supply Company.

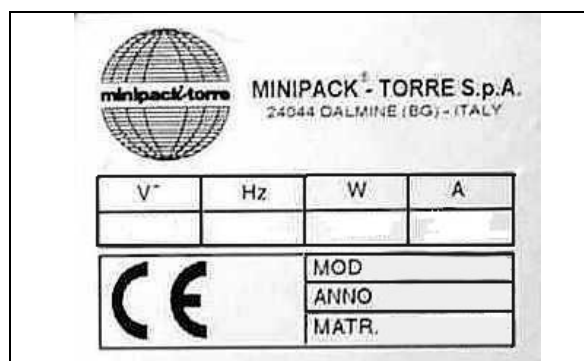

Chapter 3. Machine adjustment and setting up

3.1. Adjustment

A - Main switch

B - Sealing warning light

C - Warning light of belt advancing time

D - Pause warning light

E - Warning light of over belt speed

F - Temperature warning light

G - Programs selection button

H - Display

I - Variables selection switch

L - Adjusting button

M - Reset button

N - Piece counter display

O - Emergency button

P - Start button

Q - Start / stop button

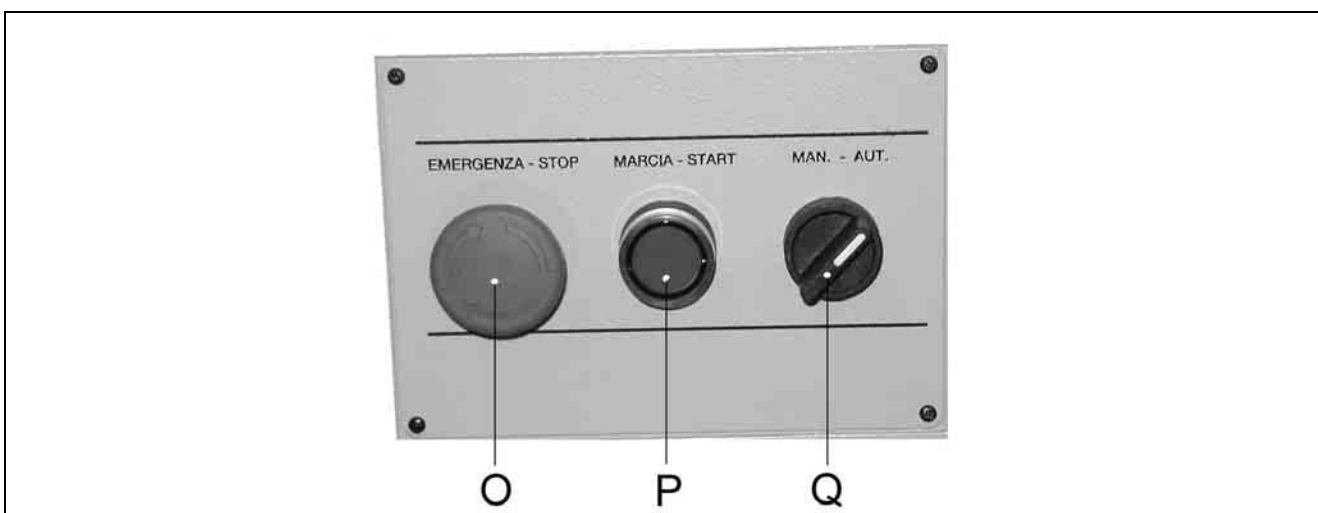
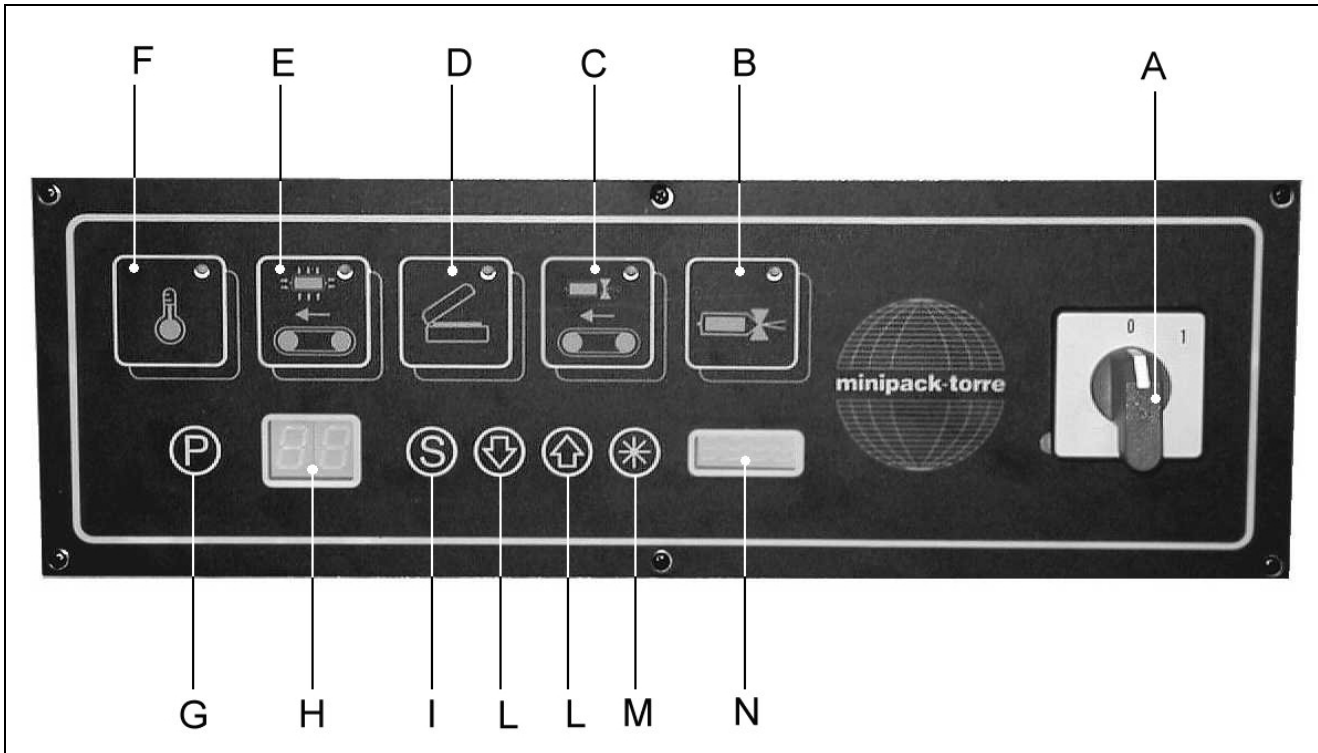

3.1. Adjustment

ELECTRONIC BOARD FEATURES

The machine is equipped with 5 selection able programs:

Program nr.	Program features
P1	Cutting only
P2	Cutting + belt advancing (no shrinking)
P3 - P4 - P5	Complete program

Each program is composed by 6 variables which can be modified:

Variable	Field	Field features
1. Time for Sealing	0 ÷ 2.7	values expressed in seconds
2. Pause time for lowered frame	0 ÷ 9 0.0 ÷ 9.9	two tenth-seconds values each point values expressed in seconds
3. Pause time for automatic cycle	00 ÷ 99 0.0 ÷ 3.0	values expressed in seconds
4. Tunnel belt speed	00 ÷ 99	corresponds to 12° ÷ 210°C (2°C each point)-
5. Sealing belt time		(medium value 75)
6. Temperature		

The machine is equipped with a piece counter to show on display (N) the number of sealings. Such a value can be put to zero at any time through reset button (M).

3.1. Adjustment

PHASE NR. 1 = SWITCHING THE MACHINE ON

Turn the main switch (A) into pos. 1. Before using the machine, wait until the adjusting temperature is reached. This is signalled by the warning light (B). Switching off display (H) turns on and the number of the currently selected program will appear.

PHASE NR. 2 = PROGRAMS SELECTION

Push button (G) to select the number of the program.

PHASE NR. 3 = VARIABLES PROGRAMMING

Through button (I) it is possible to look through the variables of the selected program, while through buttons (L) the stored values can be modified. Once the value has been set, push (I) button and then release it; the LED of the next function will light up. Set the value of the variables as previously described. To validate modifications, press button (I) until the number of the program appears on the display. Pause time"lowered frame" can be modified; there is not a LED indicating this variable which is shown with an "r" on the left display, while the right one shows the time which has been set. At the end of all variables to be adjusted, the display will show the code of the program just chosen (for example P1).

N.B.: In case during programming the SQ1 limit switch is being pressed, the unit quits the scheduling, the selected program is executed and the display shows the number of the program.

PHASE NR. 4 = PERFORMANCE

Once all adjustments have been made, the machine is ready to start working.

N.B.: tunnel units (heating elements, fan, belt) are activated in programs P3-P4-P5. In any case they are not brought into operation soon after selecting above programs, but through a manual command. When selecting one of these programs, display will show "L3" instead of "P3"; it is then necessary to press button (↑) to activate them. Exit from tunnel unit is made pressing button (↓) (display will show L3,4,5). Such an operation (exit from tunnel) has to be made before switching the machine off.

After heating has been disconnected, the tunnel belt and fan keep on functioning for a certain time (about 10 min.) before switching off, so to wait for the tunnel to cool down.

In case of "ANOMALY" the display will show as follows:

E 1	<i>Machine has been switched on when sealing frame was lowered. Lift sealing frame up.</i>
E 2	<i>Machine has been switched on when (I) button was pressed. Release button. In case the error signalling still persists, check the correct functioning of the button.</i>
E 4	<i>Temperature is higher than 300°C or feeler has been cut off. Switch the machine on to reset.</i>
E 6	<i>The limit switch to cut out security is broken (it is always closed).Check the correct functioning of the limit switch to cut out security, then switch the machine off and on again.</i>
E 7	<i>Tunnel blocked for thermic intervention of fan motor or inverter relay.</i>
--	<i>Sealing frame not in proper position when switching machine on.Press emergency button to lift hood.Once it has been lifted,signalling will disappear.</i>

3.2. Manual and automatic cycle

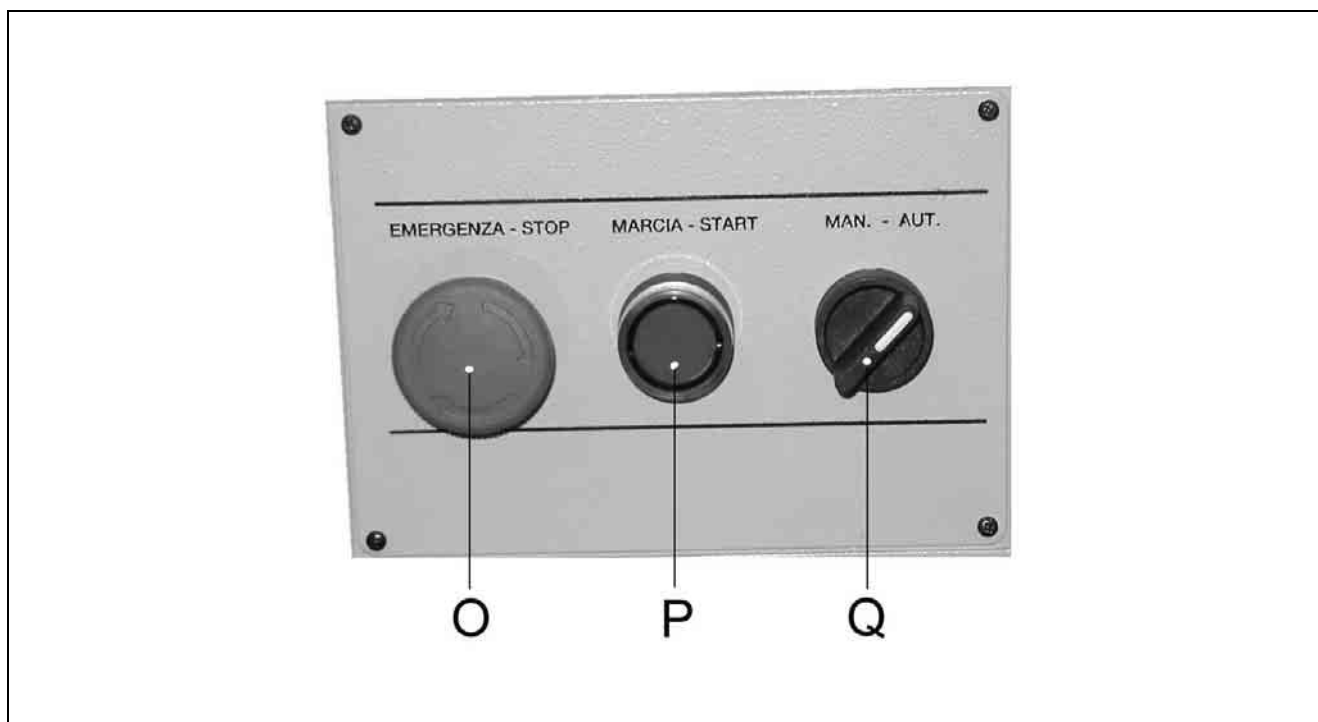

The machine can be operated with a manual as well as with in automatic cycles. To carry out only one operating cycle rotate the selector (Q) to the MANUAL-position and press the start button (P).

To operate the automatic cycle rotate the selector (Q) to the AUTOMATIC position and press the start button (P).

The machine is equipped with an **EMERGENCY BUTTON (O)** which blocks it immediately when pressed, bringing the sealing frame into start position.

The machine has also an automatic safety system on the welding frame which intervenes in case the lowering of the frame is hindered, bringing the frame back in the start position.

3.3. Film roll insertion

Insert the roll of film on the roller (1) and block it through the centering cones (2). Position the roller on the film roll support (3).

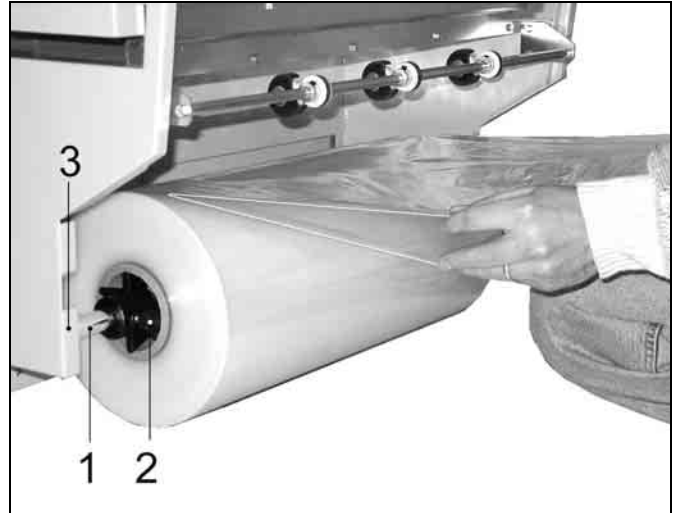

Run through the micropunches (4).

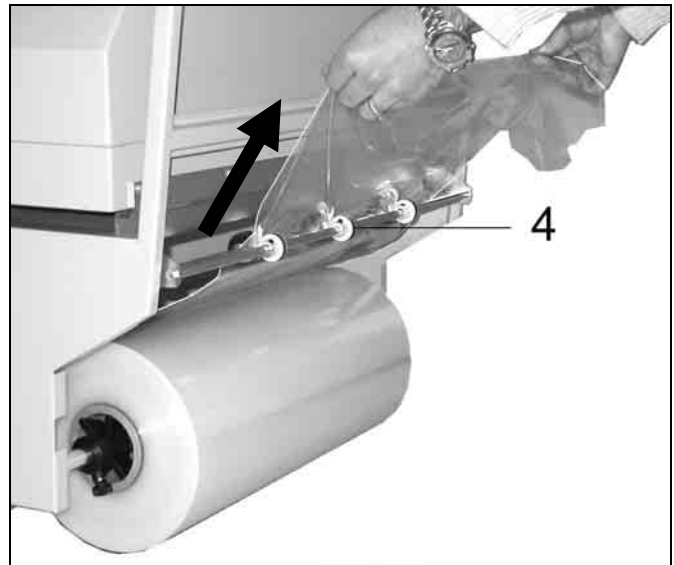

Run the film lower layer under the packaging plate (5).
Run the film upper layer over the packaging plate (5).

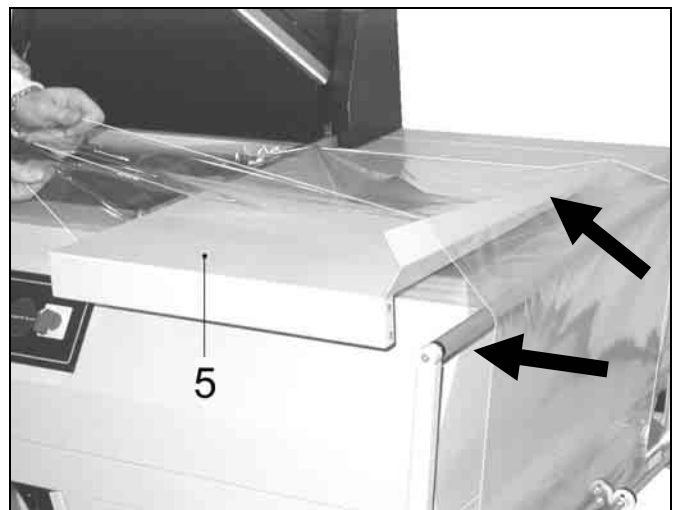

3.4. Belt adjustment

Adjust the height belt acting on the proper handwheel.

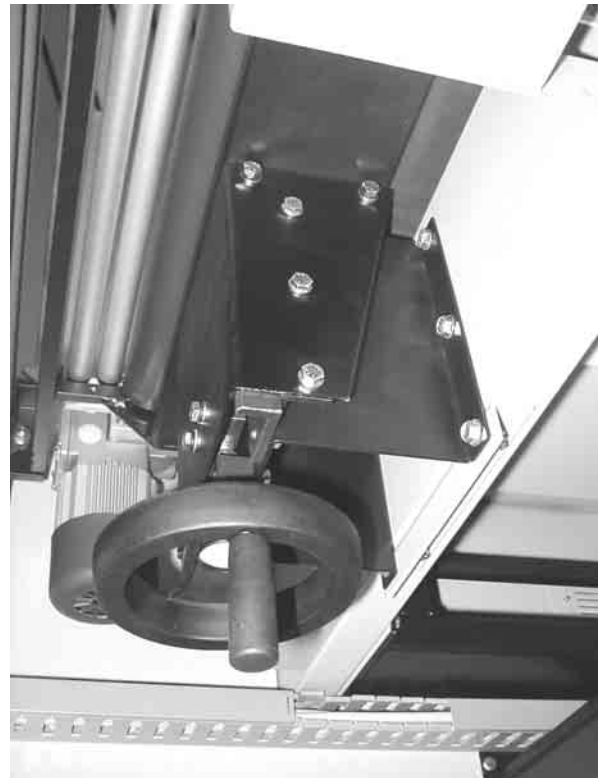

Adjust curtains acting placed on tunnel inlet on the proper knobs to get them at the same level of tunnel belt.

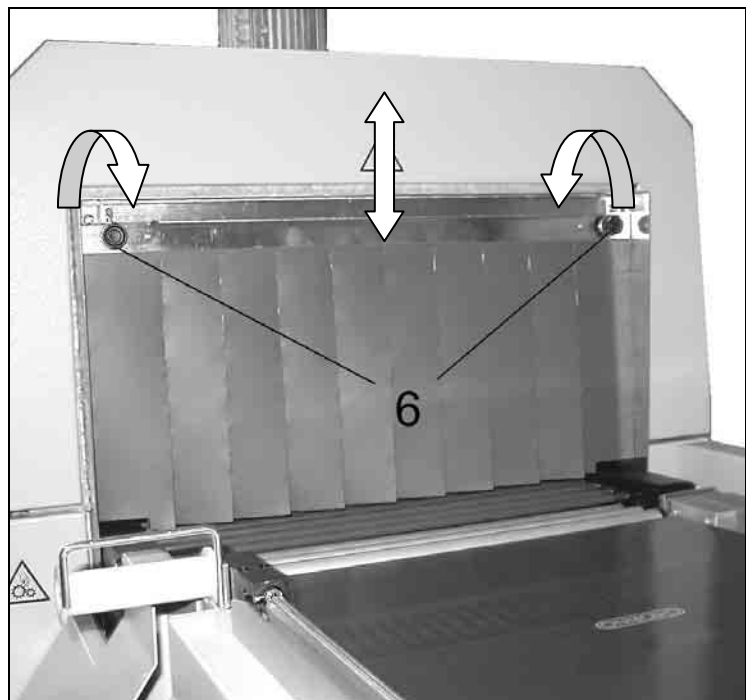

3.5. Air flow adjustment

It is possible to adjust the air flow on the product to pack by acting on the knobs (7).

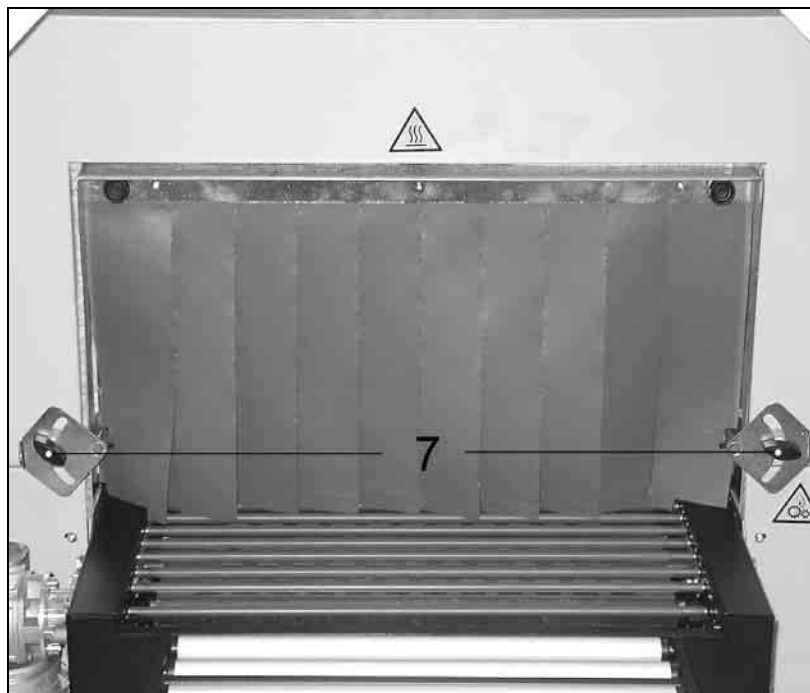

The rotation of handles (7) determines the position of the flaps (8) which drive the hot air flow into the desired direction so to obtain the best shrinking.

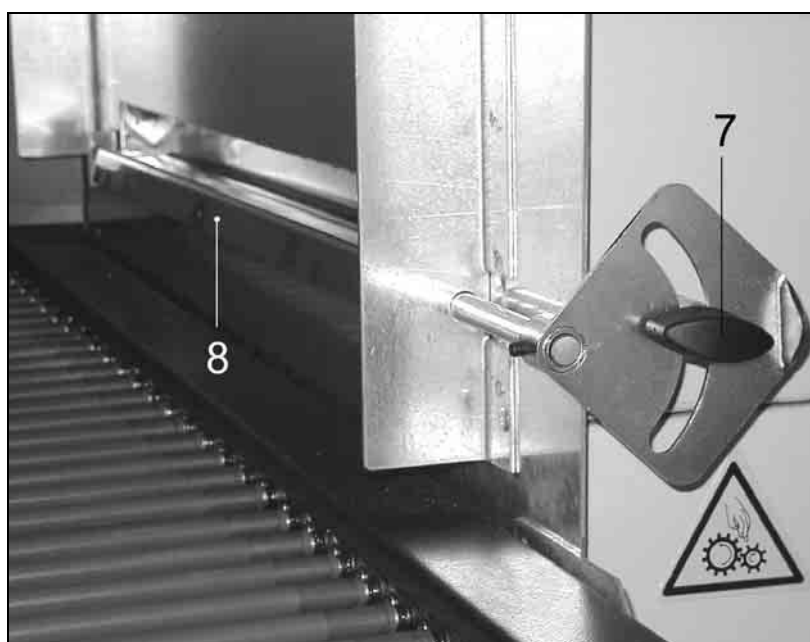

3.6. Film roll support and packaging plate adjustment

The film roll support (3) and the packaging plate (5) must be adjusted according to the width of the item to be packed, leaving about 1-2 cm between the item and the sealing edge.

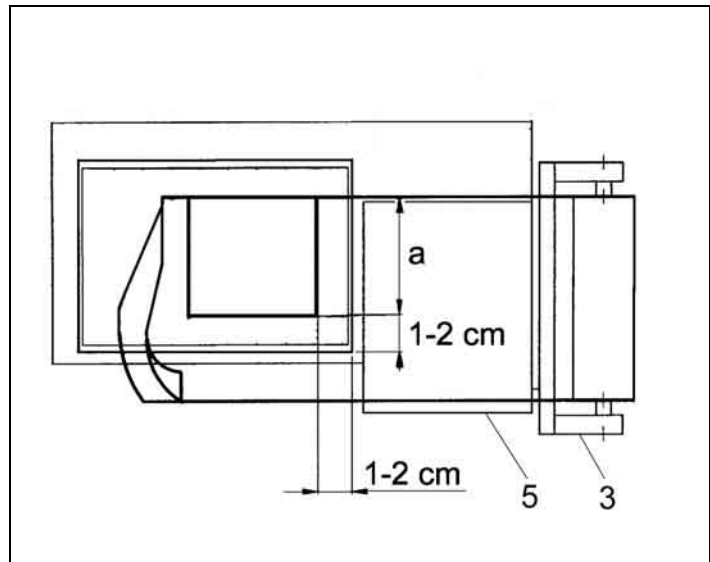

3.7. Execution of 1st film sealing

To carry out the 1st welding move the film, as shown in the figure.



Rotate the selector (Q) to MANUAL-position and press the start button (P). The machine will automatically start operating, and the first welding will be

*performed on the film's left side.
With the right hand detach the film from
the sealing blade.*



3.8. Film coupler on wrapping machine (where expected)

*Carry out a number of cycles
sufficient to make a strip of scrap
film.*



Guide this film strip around the transmission roll (9) and the driving roll (10) and couple it with the coiler (11).
The machine is now ready to start the packaging.

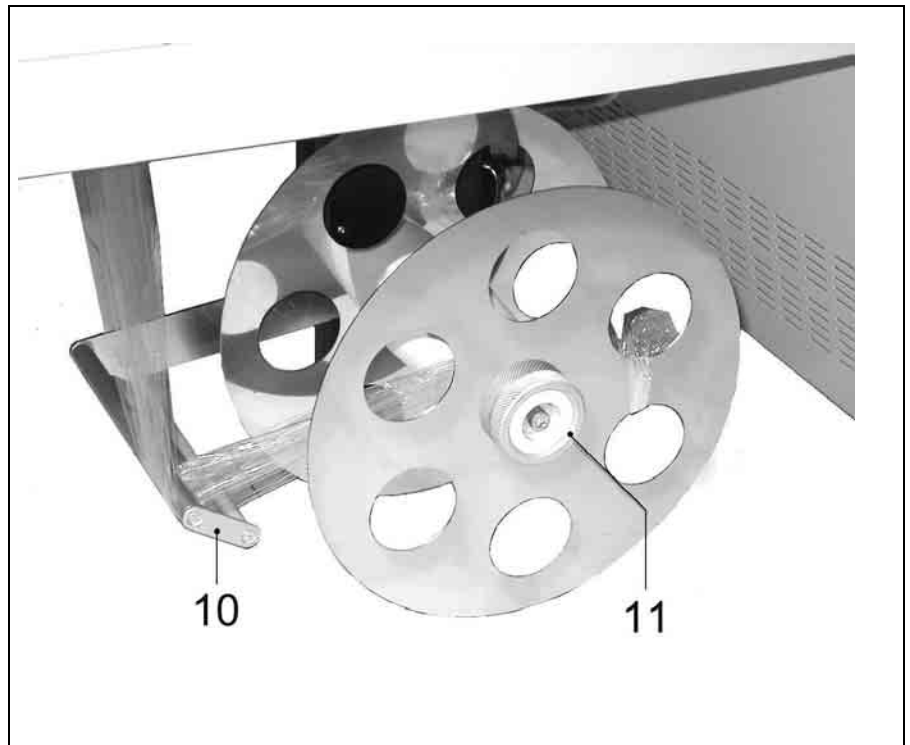

3.9. Introducing the object to be wrapped

Lift film edge on the packaging plate with your left hand. Introduce the product with your right hand into film and move it to the left until it settles on the conveyor belt leaving about 1-2 cm between the product and the outer edge of the sealing frame.



3.10. Packaging

Press the ON push-button (P).
The welding frame will automatically lower to cut and weld the film. When the frame opens again, the packed product will be fed towards the tunnel. Thus, the welding area will be released and ready to start a new welding cycle. If the machine is set to operate in automatic mode, it will restart work according to the rhythm set by programming.



Chapter 4. Limits and conditions in the use of machine

4.1. Max. packing sizes

$a = \text{mm } 550$

$b = \text{mm } 380$

$c = \text{mm } 100$

N.B.: max. dimensions shown on above scheme are referring to the max. dimension of the single package.

Refer to chapter 5.2. to get max. dimension of package ($b \times c$); the addition of ($b + c$) is equal to film roll width 100 mm.

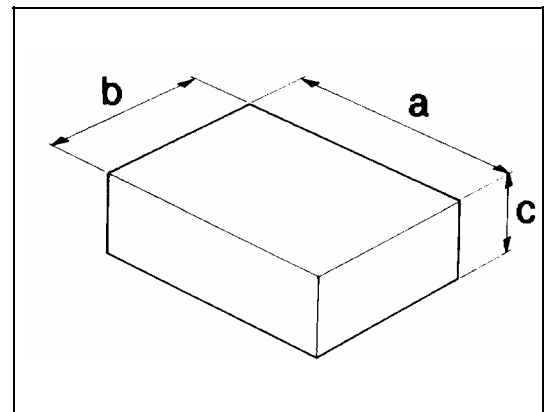

4.2. Items not to be packed

The below listed products must absolutely not be wrapped to avoid damages to the machine and serious injuries to the operator in charge: wet and unstable products, liquids of any kind and density in fragile containers, flammable and explosive materials, pressurised gas cylinder of any kind, bulk and volatile powders, any materials and products not listed but which might harm operator and cause damages to the machine.



wet and unstable products, liquids of any kind and density in fragile containers, flammable and explosive materials, pressurised gas cylinder of any kind, bulk and volatile powders, any materials and products not listed but which might harm operator and cause damages to the machine.

5.1. Films to be used

Machine can work with all shrinkwrapping films with thickness 15-50 micron manufactured by "MINIPACK-TORRE

S.p.A.". The special features of our films (which may be customized with drawings and text) assure their outstanding reliability, with regard both to compliance with laws in force and to an excellent machine performance.

A=mm 600 MAX
D=mm 300 MAX
d=mm 77

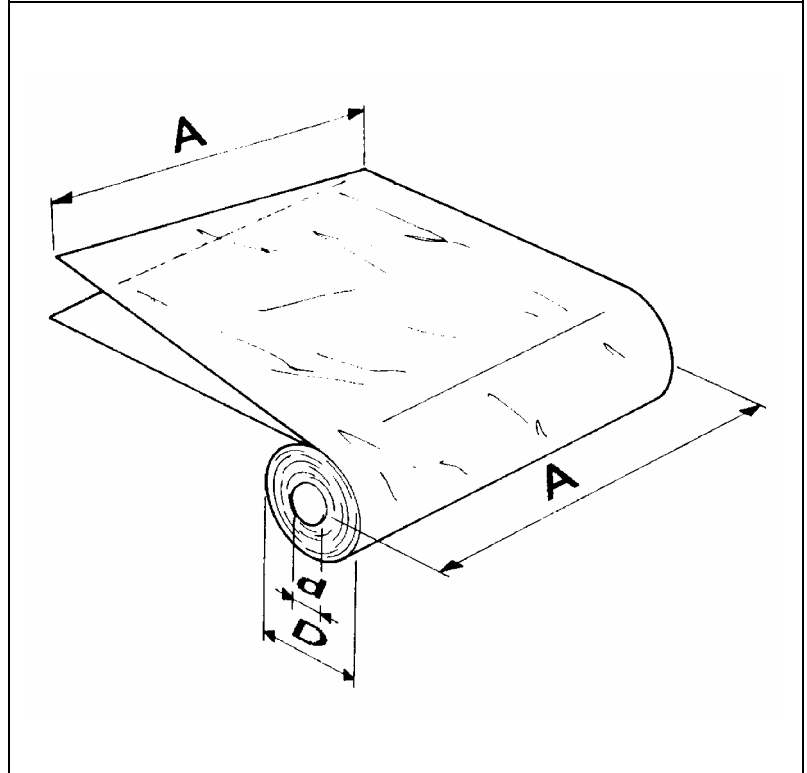

5.2. Band A calculation

Band A = b + c + 100 mm

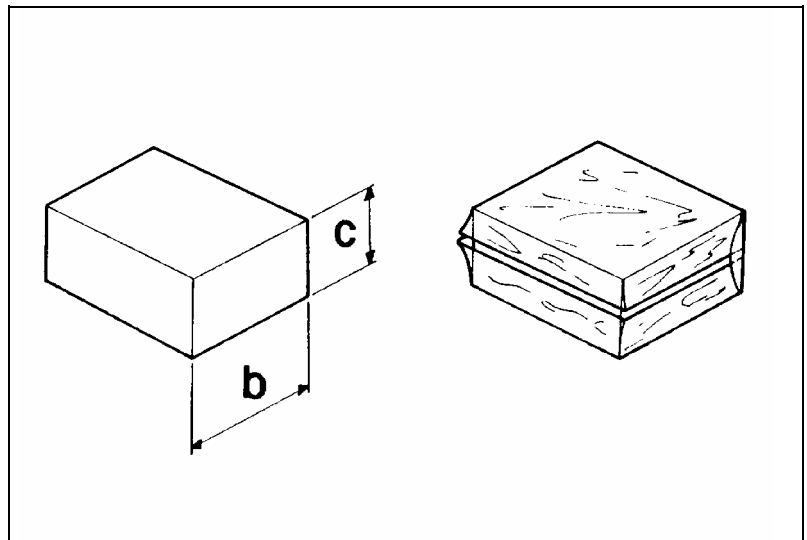

Chapter 6. Safety standards

6.1. Warnings



In case of blocking of the machine or in order to stop it during the automatic cycle press the **EMERGENCY BUTTON (O)**.



Do not touch the sealing blade (19) soon after sealing by reaching beyond the safety guard (12).

Danger of burns due to residual heat on the sealing blade.



Do not keep on sealing in case the sealing blade breaks (19).

Replace it at once.

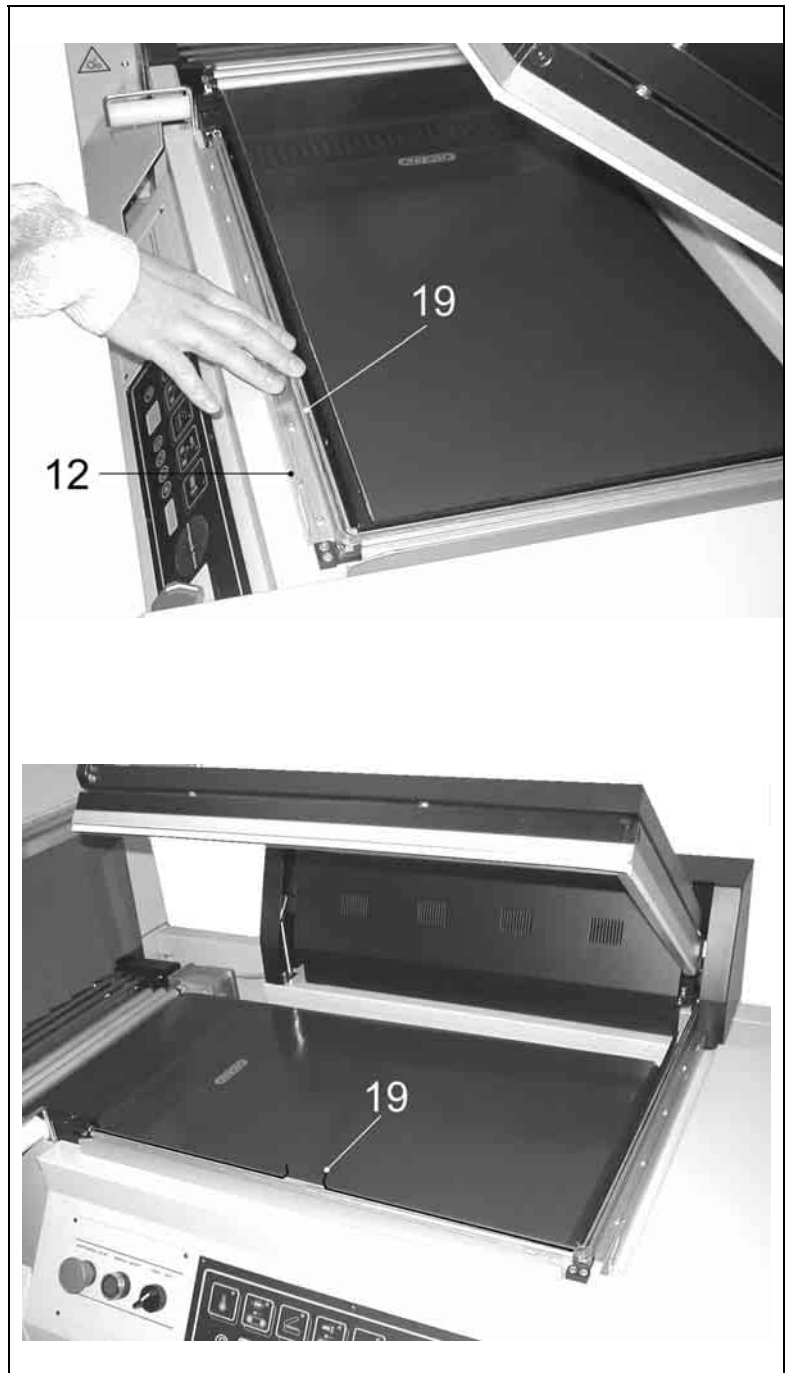

6.1. Warnings

WARNING!



Do not touch the machine hot components during the heating phase. Danger of burns!

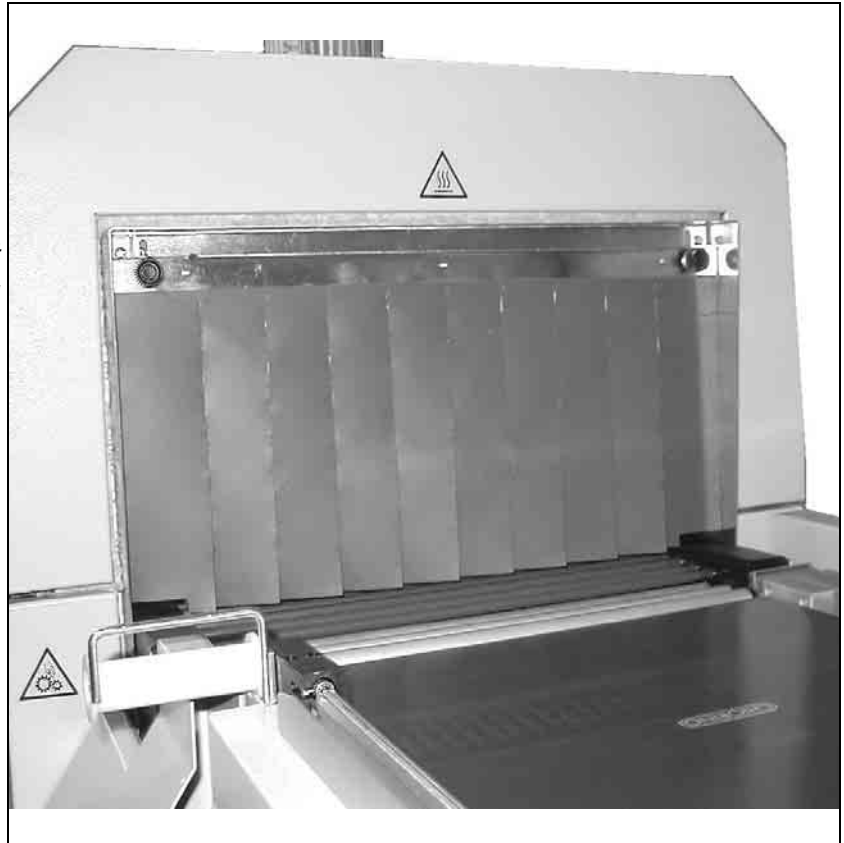

WARNING!



Do not touch the transport belt while it is moving.

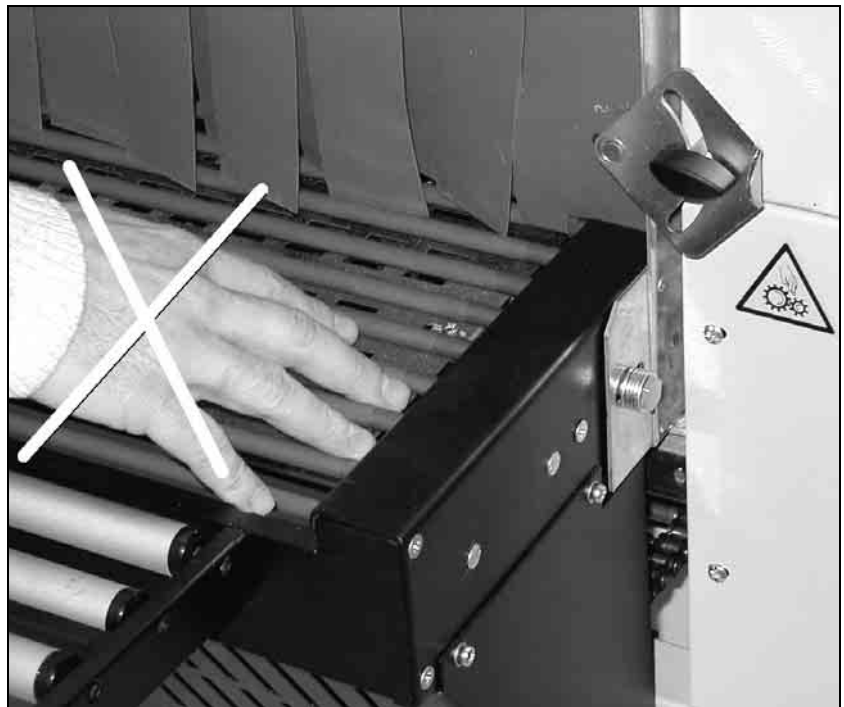

7.1. Precautions for ordinary maintenance interventions

BEFORE PROCEEDING TO MAINTENANCE, SWITCH THE MACHINE OFF AND DISCONNECT IT BY OPERATING ON THE MASTER SWITCH.

7.2. Sealing blade cleaning

Using a dry cloth, wipe off the residues clinging to the sealing wire: do this at once after sealing since they are easier to remove when still warm.



Lubricate the welding blade periodically with the supplied non-adhesive spray



7.3. Plastic film removal

It is very important to periodically clean the tunnel inside so to remove all scraps. Wait for the tunnel to cool down properly before cleaning it.

When the bobbin of the automatic coiler (15) is full, remove the film by unscrewing the knob (17) and taking away the disk (16)

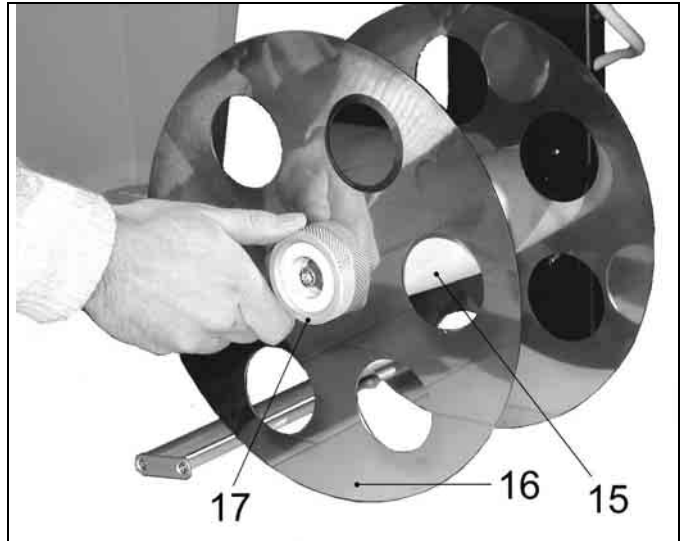

7.4. Control of cooling liquid

Check the level of the cooling fluid once every 6 months. To do so, remove the guard (R) and unscrew the plug (35).

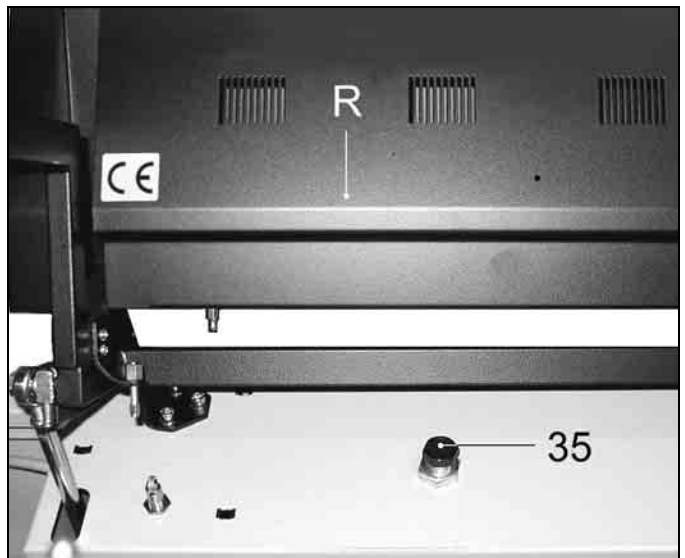

Check that the rod is wetted by the liquid at about 2 cm height; otherwise add a mixture of water and antifreeze liquid (10%).

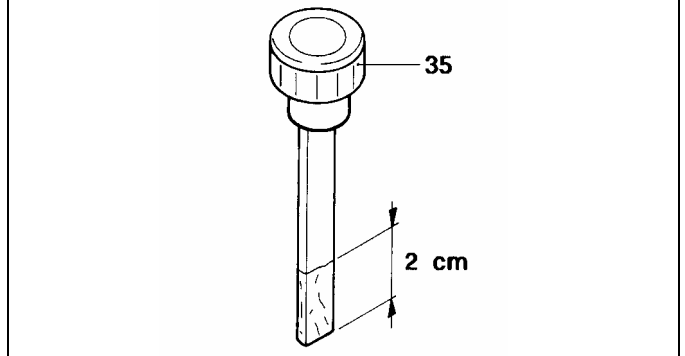

7.5. Rubber and teflon replacement

When the Teflon-stripes (13) are worn out, replace them with spare parts, paying attention that the application is linear and even. Before applying the teflon self-adhesive strip clean the rubber part (14) with a detergent.

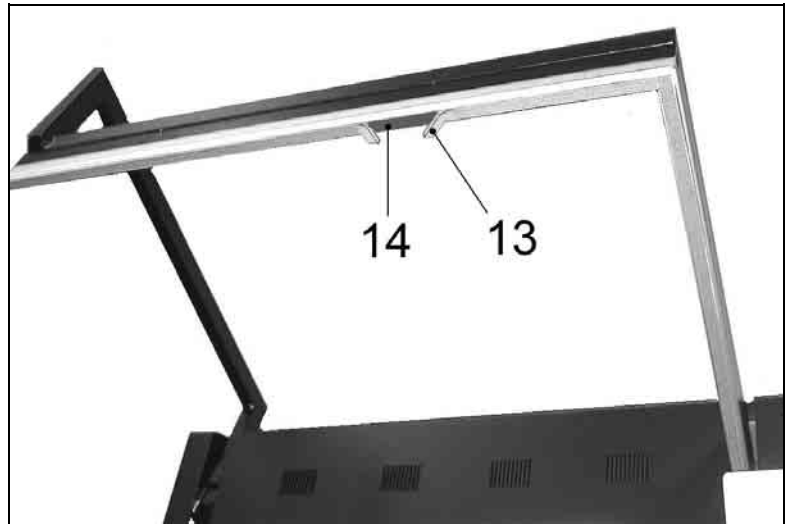

If also the rubber (14) is damaged too, replace it as follows:

Remove the old rubber, clean its housing, apply some drops of glue in the housing, insert the new rubber in a linear way, clean the rubber with a detergent, apply the self-adhesive teflon-strip.



7.6. Adjustment of the cams

Cams adjustment must be carried out only by authorised personnel!

Disassemble the panel (38) at the back of the machine to get access to the cams.

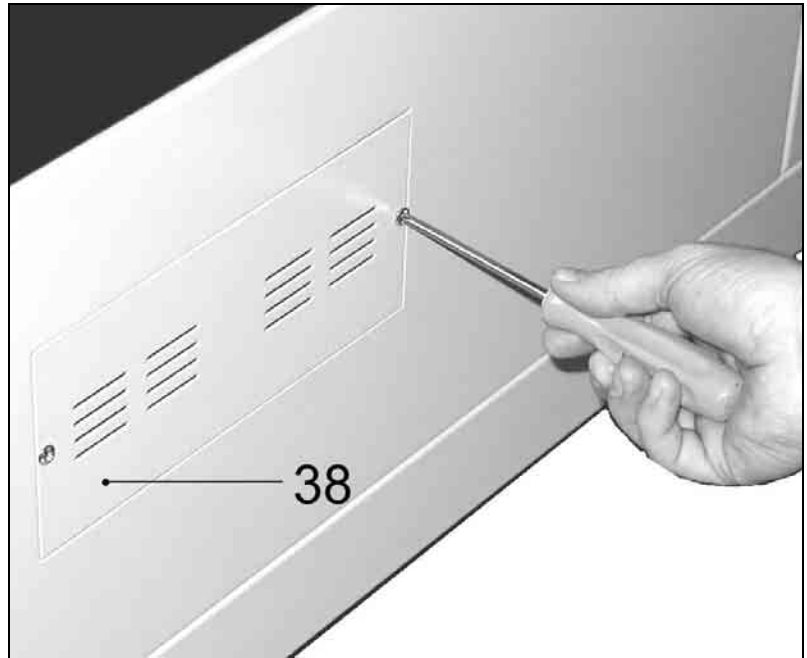

The 2 cams are adjusting:

1. Sealing frame lowering and its pressure on the sealing blade.
2. Sealing frame max opening and the start of the conveyor blade.

The adjustment is made by loosening the screw and rotating the cam in the right position.

Attention: For the cams adjustment shift them gradually.

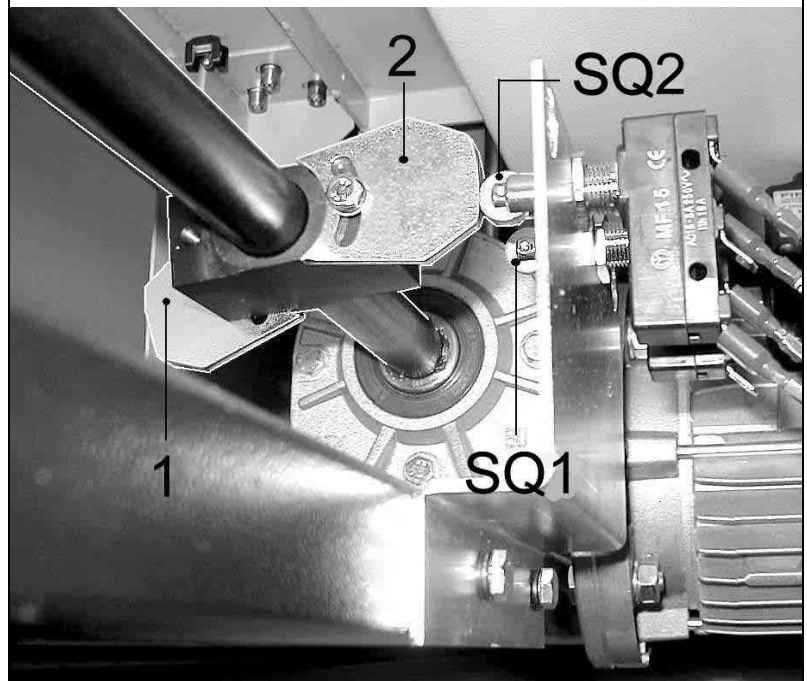

To replace the sealing blade (19) follow this procedure:

- Disconnect power to the machine
- Unscrew the three screws (20), (21), (22)
- Remove the old sealing blade
- Clean the housing and if necessary replace the insulating teflon (23) of the central clamp
- Insert the new sealing blade starting from the central clamp and tighten the screw (21)
- Trim the new sealing blade according to the holes of the pistons (24) and (25)
- Complete the insertion of the sealing blade in the whole housing
- Push the rear piston completely onwards (25) towards the sealing blade to make it enter the hole of the piston itself and then tighten screw (22)
- Insert a tool (for example a screwdriver) in hole (18) and push front piston towards the sealing blade to enter the hole of the piston itself, then tighten screw (20)
- Trim the teflon projecting from the central clamp
- Make sure that the sealing blade (19) is properly positioned and tight.

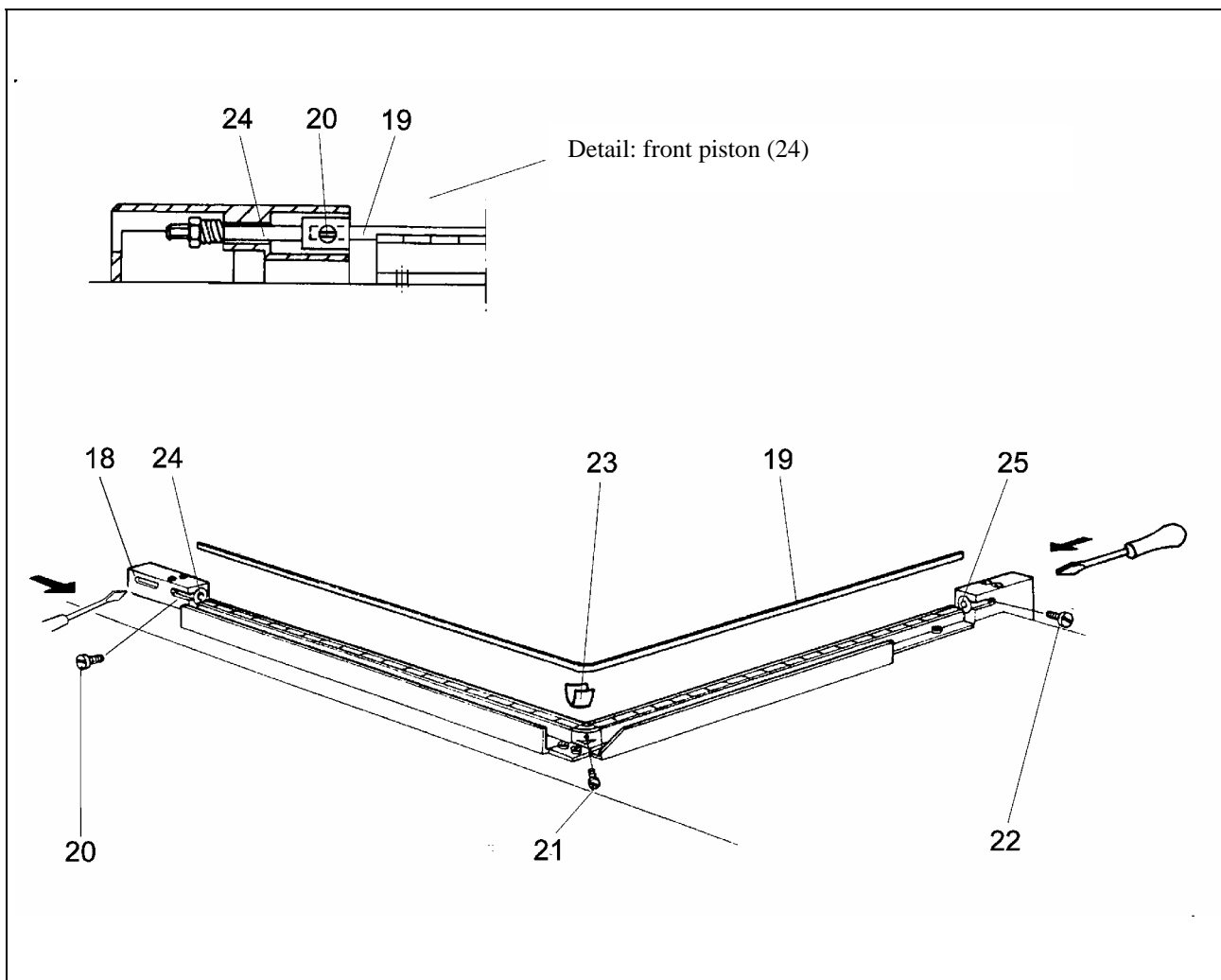

7.8. Wiring diagram

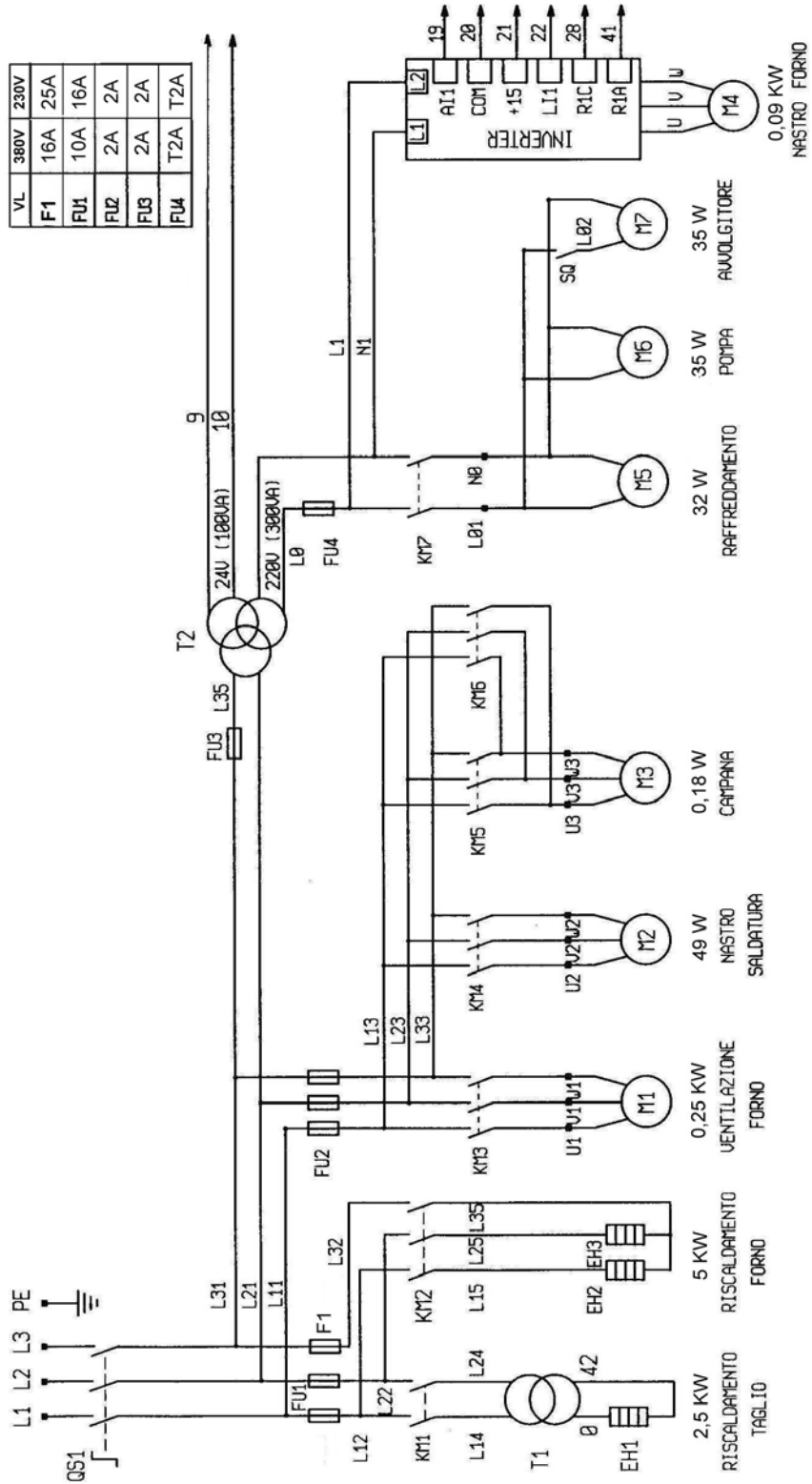

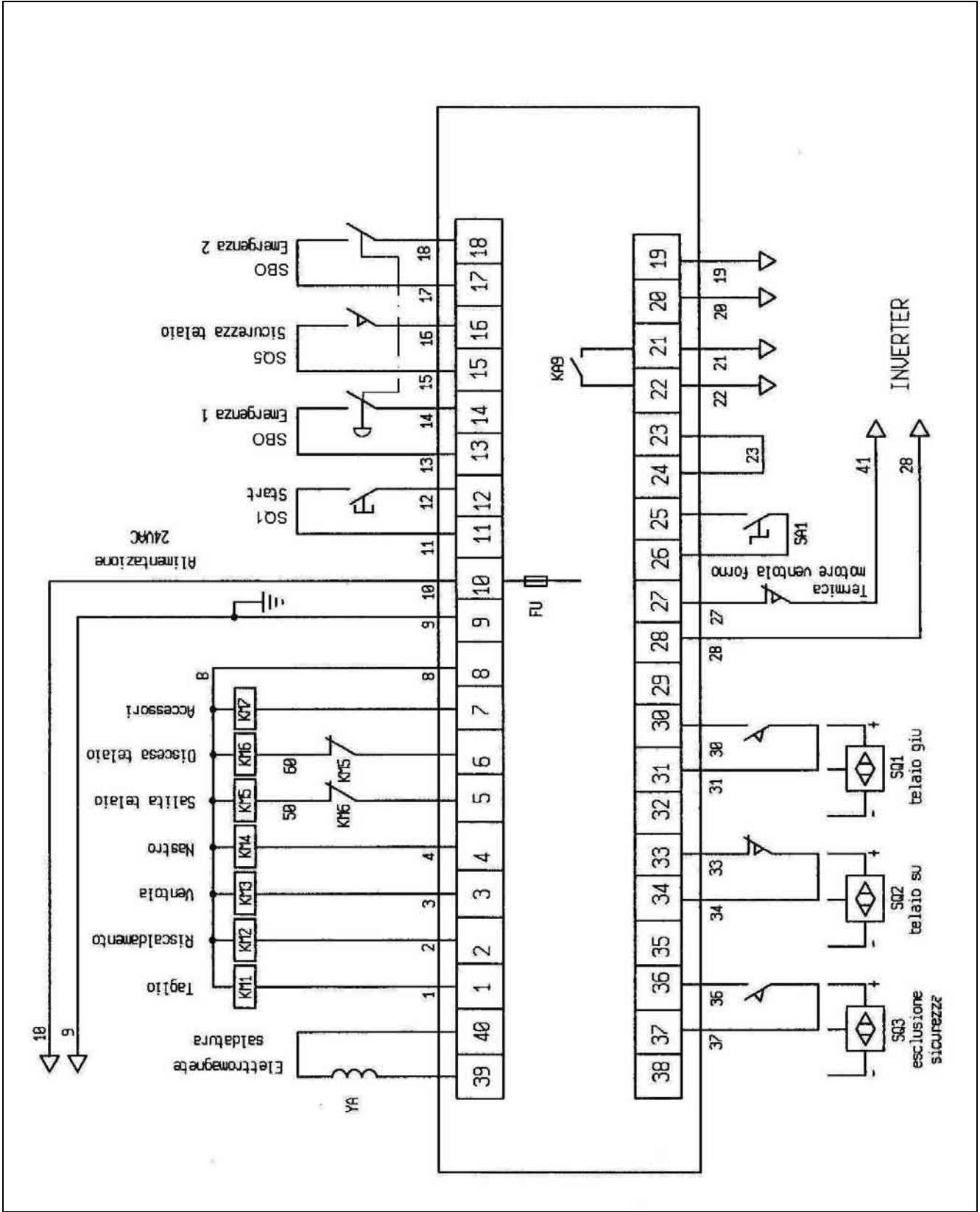

WIRING DIAGRAM DESCRIPTION

QS1	Main switch	SQ1	Frame lowering limit switch
EH1	Cutting resistance	SQ2	Frame lifting limit switch
EH2	Oven resistors	SQ3	Safety device cutting out limit switch
EH3	Oven resistors	SQ5	Safety limit switch
EH4	Oven resistors	KM1	Cutting contactor
M1	Fan motor	KM2	Oven resistors' contactor
M2	Belt motor	KM3	Fan contactor
M3	Frame drive motor	KM4	Sealing Belt contactor
M4	Belt oven motor	KM5	Bell descent contactor
M5	Ventilator motor	KM6	Bell rise contactor
M6	Pump motor	KM7	Fittings contactor
M7	Winder motor	SB0	Emergency button
T1	Cut transformer	SB1	Start button
T2	Auxiliary transformer	SA1	Manual selector
SQ	Winder limit switch	YA	Sealing magnet
		SP	Foot Pedal

7.10. Spare parts

Code	Item description		
S08A0404	Teflon liner		
FE385602	Sealing blade		
S0K00306	Complete central terminal		
S0K00302	Complete rear terminal		
S0K00301	Front blade holder clamp		
S03A0606	Complete slotted microperforator		
S03A0605	Complete needles microperforator		
FE380016 (380V)	Resistors		
E240070 (230V)	Fan motor		

Chapter 8. Guarantee

Model and Serial Number:

Equipment manufactured by minipack-torre *is* warranted to be free of defects in parts and craftsmanship for a period of one (1) year from the date of installation, or 15 months from the invoice, whichever occurs first, minipack-america's exclusive obligation under this warranty is limited to repairing or, at its option, replacing any minipack-torre part that is determined by minipack-america to be defective. The warranty is for the original purchaser of new equipment.

Component subsystems manufactured by minipack-torre carry the warranty as stated herein. The warranty does not apply to subsystem component parts which are not manufactured by minipack-torre. Subsystem component parts not manufactured by minipack-torre shall be subject to any warranty of its manufacturer.

This warranty shall not apply to damage resulting from installation, modification, or repair by anyone other than a minipack-america authorized distributor/dealer. Nor shall it apply to any equipment which has been subject to accident, alterations, neglect, misuse or improper maintenance.

In the event of highly corrosive or high moisture applications, special protective coatings or stainless steel construction might be needed.

minipack-torre and minipack-america shall not be liable if minipack-torre equipment or components are used with accessory equipment not manufactured by minipack-torre.

Representations and/or warranties, by whomever made (even if made by minipack-america authorized distributors/dealers), which are inconsistent with the terms herein shall not constitute a term of the minipack-torre or minipack-america express warranty and shall not be binding on minipack-torre or minipack-america.

THE LIMITED WARRANTY SET FORTH ABOVE IS THE SOLE AND ENTIRE WARRANTY PERTAINING TO THE PRODUCT AND IS IN LIEU OF AND EXCLUDES ALL OTHER WARRANTIES OF ANY NATURE WHATSOEVER, WHETHER EXPRESSED, IMPLIED OR ARISING BY OPERATION OF LAW, INCLUDING, BUT NOT LIMITED TO ANY IMPLIED WARRANTIES OF MERCHANTABILITY OR FITNESS FOR A PARTICULAR PURPOSE. THIS WARRANTY DOES NOT COVER OR PROVIDE FOR THE REIMBURSEMENT OR PAYMENT OF INCIDENTAL OR CONSEQUENTIAL DAMAGES OF ANY TYPE, MANNER OR DEGREE, AND ANY LIABILITY BY MINIPACK-TORRE OR MINIPACK-AMERICA FOR SUCH INCIDENTAL OR CONSEQUENTIAL DAMAGES IS HEREBY DISCLAIMED. Some states do not allow this exclusion or limitation of warranties and/or damages, so the above limitations and/or exclusions might not be applicable to you. This warranty gives you specific legal rights, and you might also have other rights that vary from state to state.