



MV48DV

Instruction manual



Before using the machine please carefully read the instructions



DOC. N. FM111038
REV. 0
ED. 01.2001

INDEX

Chapter 1. Foreword

- 1.1. Introduction.....
- 1.2. Performances of packaging machine.....
- 1.3. Machine identification.....
- 1.4. Weight and dimensions of packed machine.....
- 1.5. Machine weight and dimensions.....

Chapter 2. Machine installation

- 2.1. Transport and positioning.....
- 2.2. Environmental conditions.....
- 2.3. Electrical connections.....
- 2.4. Gas connections.....

Chapter 3. Machine adjustment and setting up

- 3.1. Adjustment.....

Chapter 4. Limits and conditions in the use of machine

- 4.1. What shall not be packed.....

Chapter 5. Bags features

- 5.1. Bags fit for use.....

Chapter 6. Safety standards

- 6.1. Warnings.....

Chapter 7. Ordinary maintenance

- 7.1. Precautions for ordinary maintenance interventions.....
- 7.2. Cleaning of the welding bar.....
- 7.3. Replacement of the Teflon and the welding blade.
- 7.4. Replacement of the cover gasket.....
- 7.5. Cleaning of the machine.....
- 7.6. Pump oil change.....
- 7.7. Wiring diagram.....
- 7.8. Key wiring diagram.....
- 7.9. Pneumatic diagram.....
- 7.10. Spare parts.....
- 7.11. Disassembling, demolition and elimination of residuals.

Chapter 8. Guarantee

- 8.1. Certificate of guarantee.....
- 8.2. Guarantee conditions.....
- 9.1. EC declaration of conformity.....

Chapter 1. Foreword

1.1. Introduction

You have bought a machine with outstanding features and performance and we thank you very much for your confidence in choosing it.

The MINIPACK System is unique in its kind and has achieved worldwide success with more than 50000 units operating in the field of packaging and wrapping. It is handy, low-priced and protected by patents at home and abroad. The technological concept underlining its design, as well as the components and materials used in the manufacturing and testing process are the best assurance of proper operation and long-lasting liability.

1.2. Performances of packaging machine

This machine represents what the modern technology of vacuum-packing may express at its best. It is flexible, easily programmable and inexpensive.

It is intended to vacuum-pack foodstuffs by removing oxygen as well as any chemical and biological pollutant present in the environment.

To attain the vacuum level you wish, just program the machine in order to remove almost all the air contained in the packet.

Your product will preserve its organoleptic features, colour, taste, flavour and nutritive value for a long time.

1.3. Machine identification

In every communication with the Manufacturer, always mention the model and the serial number specified on the plate on the rear part of the machine.



1.4. Weight and dimensions of packed machine

A = mm 1590

B = mm 960

C = mm 1200

Peso = Kg 307

Weight = Kg 307

Gewicht = Kg 307

Poids = kg 307

Peso = Kg 307

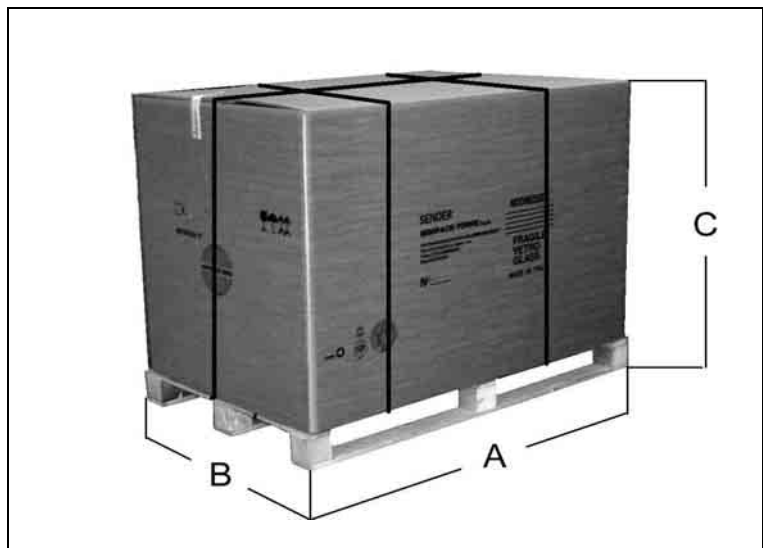

A = 1230 mm
B = 760 mm
C = 1420 mm
Peso = Kg 275

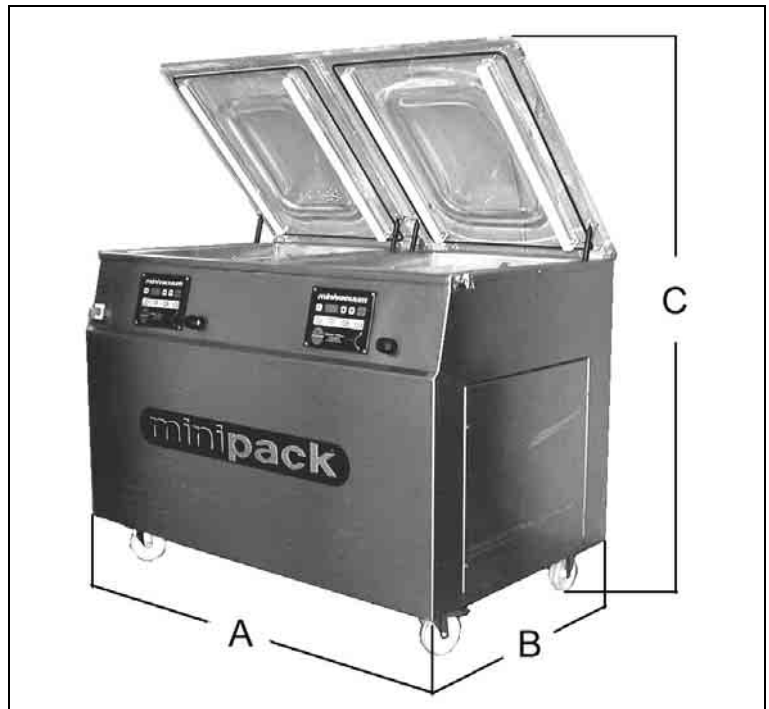

Chapter2. Machine installation

2.1. Transport and positioning

When transporting and positioning the machine, it is recommended to handle it with great care!

Neither overturn nor tilt the machine! Oil might come out of the pump and damage the machine.

- Cut the strap (B).
- Remove the upper carton (A).
- Cut the strap (C) fastening the machine to the pallet.
- Lift the machine and place it on the work bench. Make sure the machine is placed in a proper environment without any inflammable, gas, explosive.

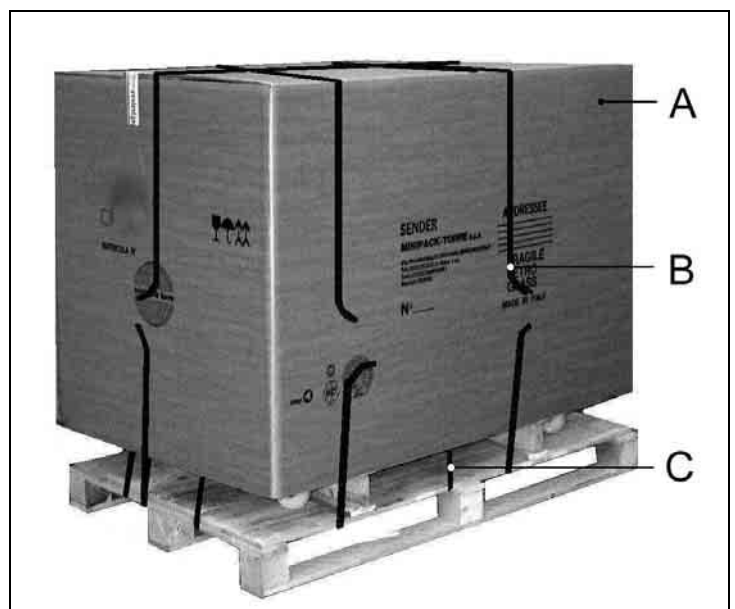

2.2. Environmental conditions

Working environmental conditions:

- Temperature from + 5°C to + 40°C
- Relative humidity from 30% to 90%, without condensation

Machine safety factor = IP20

The aerial noise made by the machine is lower than 70dB

2.3. Electrical connections

GROUNDING OF THE UNIT IS OBLIGATORY!

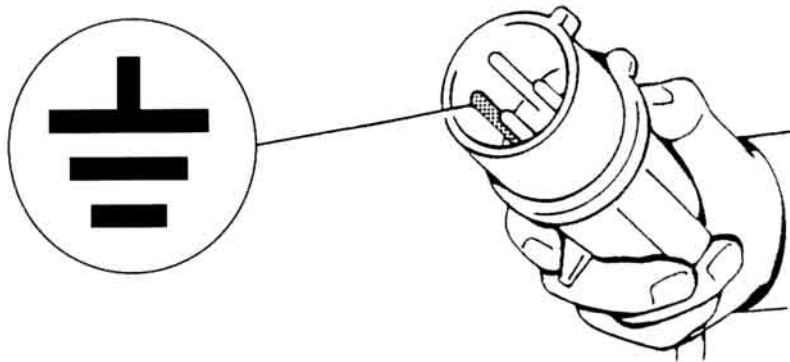

Before executing electrical connections (13), make sure the mains voltage matches the one on the plate (14) on machine rear and that the earthing contact complies with the safety rules in force. In case of doubts about the mains voltage, contact the local public supply Company.



2.4. Gas connection

Connect gas attachment (15), in case the machine is equipped with such a device, to the gas cylinder through the proper tube (T).

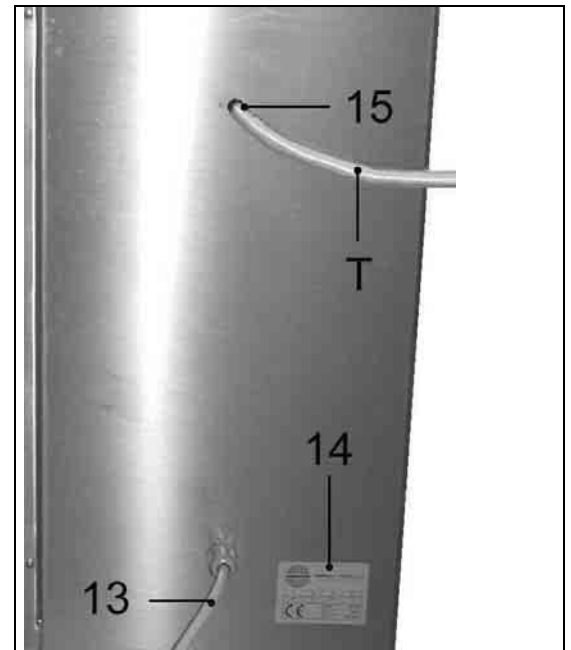

Pressure of gas plant has to be set on about 2 atm., bearing in mind the max. Working pressure is 4 atm.

If the pressure is not correct, act on the knob of the pressure reducer (R).

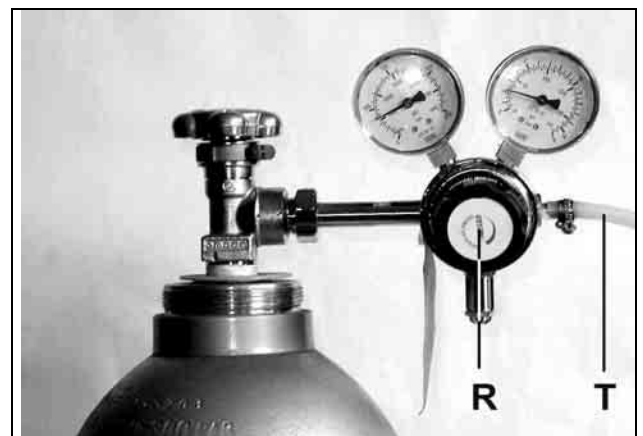

Chapter 3. Machine adjustment and setting up

CALIBRATION INSTRUCTIONS:

To maintain the highest level of accuracy we recommend you recalibrate this machine at its final destination. Atmospheric pressure differs from location to location and Calibration insures the highest level of accuracy.

Step 1- Connect machine to the power source.

Step 2- Hold down the ↑↓ arrows simultaneously.
Switch the machine to the “ON “position.
Display illuminates CAL, now release the arrows.

Step 3- Close the lid, the cycle will start and the digital display will increment up.
When the digital display stops incrementing, note the number.
Press the S key and the cycle will end.

Step 4- At cycle end the lid opens automatically and the display returns to P-1
Switch the machine to the “OFF” position.

Step 5- Repeat steps 2 and 3.
Before step 3 levels off press the S key 1 digit under the noted number.
(Example: If the digital display stops incrementing at 240. On step 5, press the S key at 239)

The machine is now ready and calibrated to its own environment.

3.1. Adjustment

1. Main switch
2. Control panel
3. Adjusting knob for air re-immission



4. Selection button
5. Display
6. Regulation button
7. Regulation button
8. Stop button
9. LED for vacuum and extra vacuum function
10. LED for gas function
11. LED for sealing function
12. LED for air re-immission function

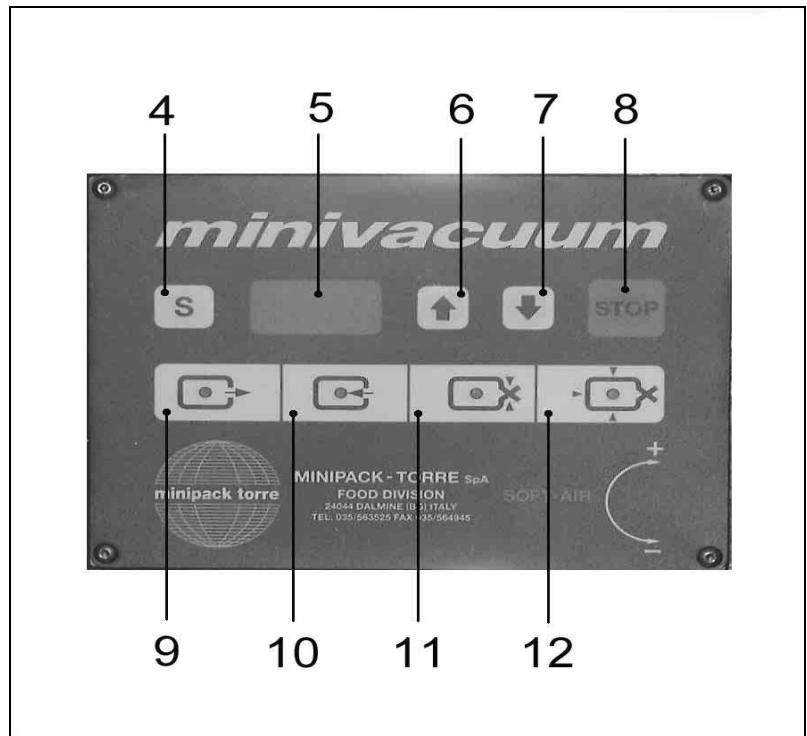

3.1. Adjustment

FEATURES OF THE ELECTRONIC CARD

The machine has 9 selectable programs. Each program is made of 4 changeable variables.

Variable	Field	Field Features
1. Vacuum	0 ÷ 99,9	Values expressed in %
2. Extra vacuum	0 ÷ 30	Values expressed in seconds
3. Gas	0 ÷ 99	Values expressed in % (never exceed 50%)
4. Welding	0 ÷ 4	Values expressed in seconds

All packaging machines are tested at works. The parameters set at works generally prove to be fit for use.

PHASE 1 = START-UP

Switch (1) the main switch (1). As soon as the board has been switched on, display will show the software version, then the last program being executed (P1÷P9).

PHASE 2 = PROGRAMS SELECTION

To select the program number, just press the buttons (6) and (7).

PHASE 3 = VARIABLES PROGRAMMING

Press button (4) to enter scheduling of the program shown at the moment. By pressing again button (4), all parameters for the selected program will appear one after the other. Push buttons (6) and (7) to increase or decrease the value of the parameter shown. Parameters are stored when, while running a program, the number of the program itself will appear on the display.

1) VACUUM

It is possible to set a value from 0 to 99,9%. The recommended vacuum percentage is 99,9%. Scheduling of vacuum parameter is signalled through LED (9).

2) EXTRAVACUUM

You enter scheduling of such a parameter when going beyond value 99,9%. Extra vacuum parameter is shown on the display through letter "E"; its value is included between 0 and 30 seconds. During this time the pump keeps on extracting air from the hood after the machine has reached the adjusted vacuum level. This function is useful especially when packing porous products as it is quite difficult to extract air from them (for example: meat).

3) GAS

It is possible to set a value from 0 to 99,9%. Such a parameter cannot be higher than the vacuum one, otherwise you will obtain an opposite function. Scheduling of gas parameter is signalled through LED (10). If the gas LED (10) is flashing, it means the gas cylinder is not properly connected and machine will not start. Connect it properly.

N.B.: When scheduling a program "vac + gas", the minimum residual vacuum percentage soon after gas immission should be higher than 50%

Example: VAC 99% GAS 49% Residual vacuum (99-49)= 50%

4) SEALING

It is possible to set a value from 0 to 4 seconds. For the first working cycles it is recommendable to set a sealing time of about 2,5 seconds and then lower it to prevent the teflon tape from burning. Scheduling of sealing time parameter is adjusted through LED (11).



- ❑ **Functions adjustment has to be done on both boards which are independent one from the other and can be adjusted with different values.**
- ❑ **The two vacuum chambers of the machine cannot work at the same time.**

PHASE 4 = EXECUTION

Place the bag inside the bell and on the welding bar in a way as linear as possible. Try to prevent the bag from wrinkling. Wrinkles might negatively affect the hermetic seal formed by welding.

Bags shall be at least 2 cm beyond the welding bar.

Lower the upper Plexiglas cover.

The machine will start executing its working cycles.

After every working cycle, on the display will appear a number showing the total cycles being executed.

All set-up parameters are stored until they are modified.

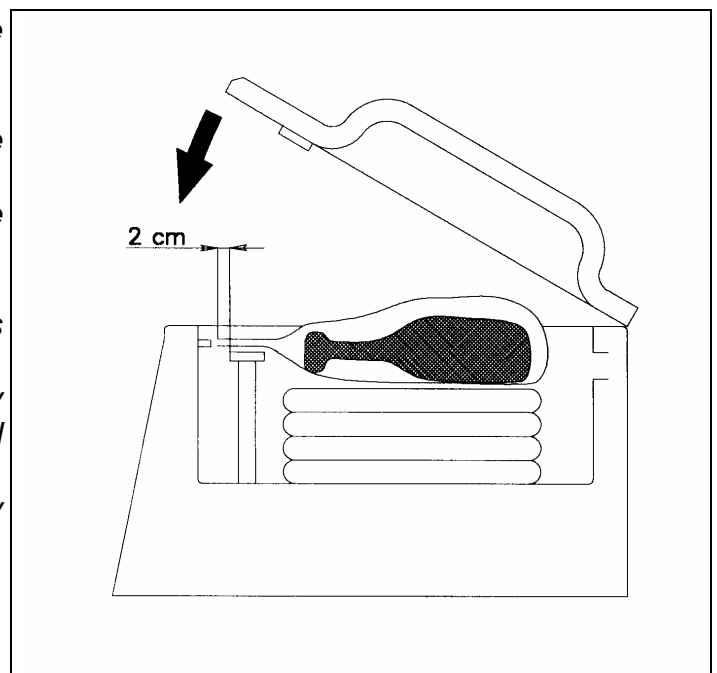

N.B.: if you press the **STOP** button (8), the machine will immediately stop sucking and automatically start welding the bag.

This function will be used to pack liquid and hot products which may start boiling during the vacuum cycle.

After you have closed the upper cover, the packaging cycle will start. It consists of 4 phases:

- *Suction phase during which all the air contained inside the bell and the bag is sucked.*

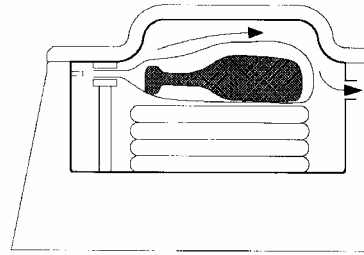

- *Gas injection phase (if the machine is equipped with a gas plant).*

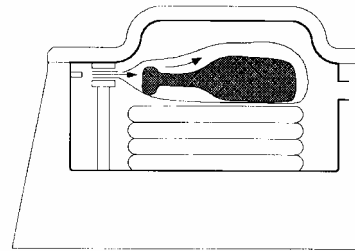

- *Welding phase during which the packet is sealed.*

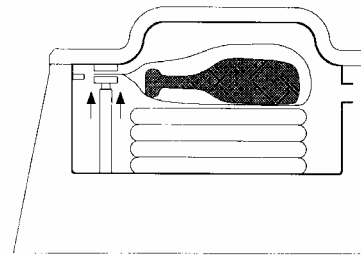

- *Air re-enter phase and subsequent opening of the cover.
The bell will reach its atmospheric pressure and the upper cover will open again.
The machine is ready for a new packing cycle.*

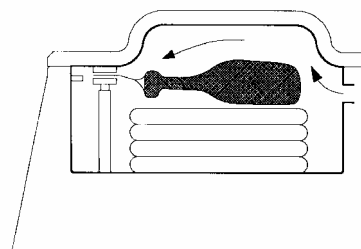

Chapter 4. Limits and conditions in the use of machine

4.1. What shall not be packed

It is absolutely forbidden to pack the following types of products which might permanently damage the machine and *cause the operator to be in a dangerous situation.*



- *Liquids of any type and density in fragile containers*
- *Inflammables*
- *Explosives*
- *Gas bottles under pressure or of any type*
- *Dissolved or volatile powders (unless a filter is mounted on the pump)*

Any material and product which might in any way cause the user to be in a dangerous situation and damage the machine

Chapter 5. Bags features

5.1. Bags fit for use

To achieve the best results it is recommended to use the bags commercialized by MINIPACK TORRE SPA.

Our bags are highly reliable. They have been specifically developed to comply with the regulations in force and are perfectly fit for use on our machines.

Bags may be of different thickness and shall be both airtight and gastight.

Chapter 6. Safety standards

6.1. Warnings



Never touch the welding bar (16) immediately after welding.

You might burn because the bar is hot.

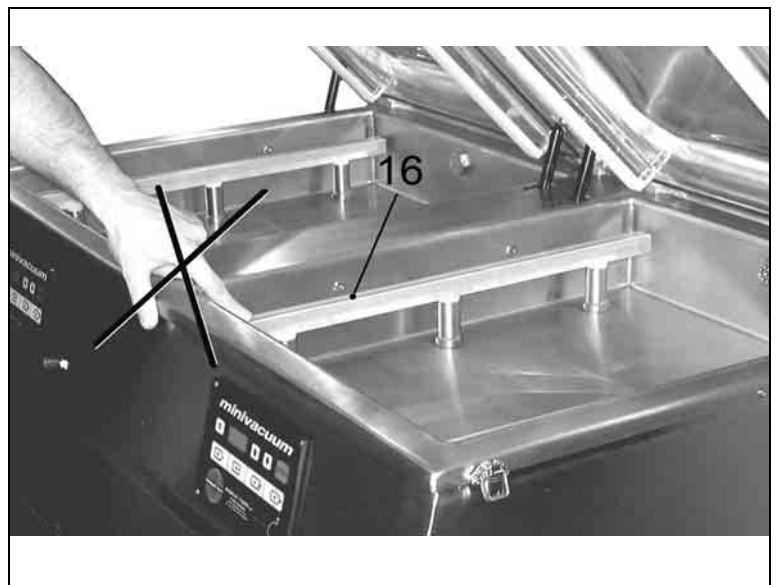

Chapter 7. Ordinary maintenance

7.1. Precautions for ordinary maintenance interventions

BEFORE ANY ROUTINE MAINTENANCE SWITCH OFF THE MACHINE BY ACTING ON THE MAIN SWITCH AND REMOVE THE PLUG FROM THE MAINS SOCKET. DISCONNECT THE PLANT GAS.

7.2. Cleaning of the welding bar

Use a dry cloth to remove any film residue on the welding bar (16). Carry out this operation just after each welding cycle.

Residues are still hot and may be easily removed.

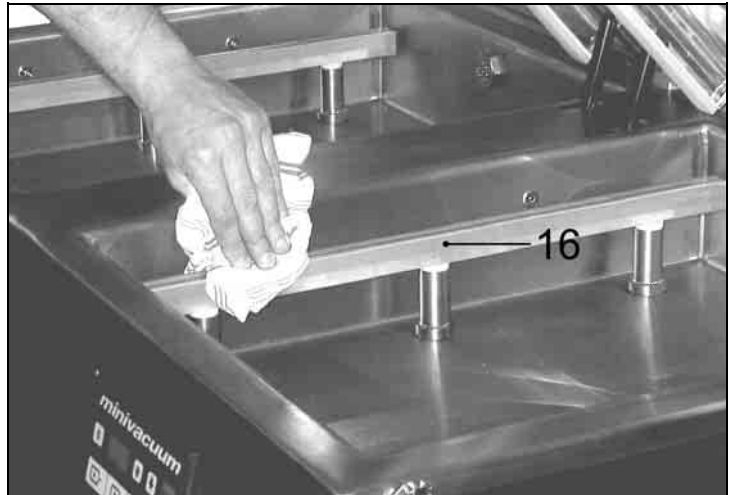

7.3. Replacement of the Teflon and the welding blade

Before replacing the Teflon and the welding blade wait for the machine to be properly cooled.

- Remove the welding bar (16) from its seat.
- Remove the Teflon adhesive tape.
- Unscrew the screws fastening the blades to each end of the welding bar.
- Tighten the new blades. Make sure they are tout enough before blocking them.
- Use the Teflon adhesive tape to cover the welding blades.

Place the welding bar into its seat.

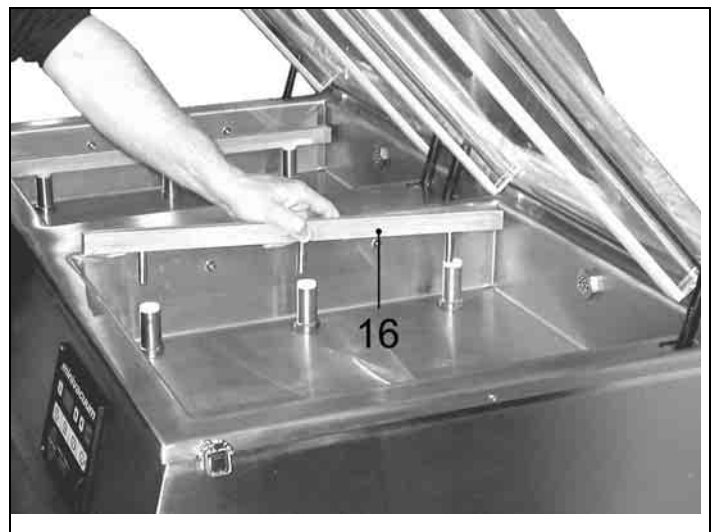

7.4. Replacement of the cover gasket

When the cover gasket (17) is worn, replace it. This will improve the efficiency of the machine and increase its speed rate.

Replacement is very easy. After having removed the gasket which has worn up, clean its seat and insert the new gasket in a linear way. Make sure its ends are joined. Leave no opening which might prevent the product from being properly vacuum-packed.



7.5. Cleaning of the machine

Use a normal wet cloth to clean the Plexiglas bell.

Never use detergents or solvents which might damage the bell and reduce its transparency as well as its resistance. Use normal detergents for stainless steel to clean the case and the internal tank.



7.6. Pump oil change

Every 3-4 months check the oil level in the pump by removing the front panel. Change the pump oil in case of a change in color due to the presence of powders or liquids. Completely change the pump oil every 250 working hours or at least once a year (use the hydraulic oil of the type specified on the pump).

(A) PLUG FOR OIL EMPTYING (to completely replace old oil)

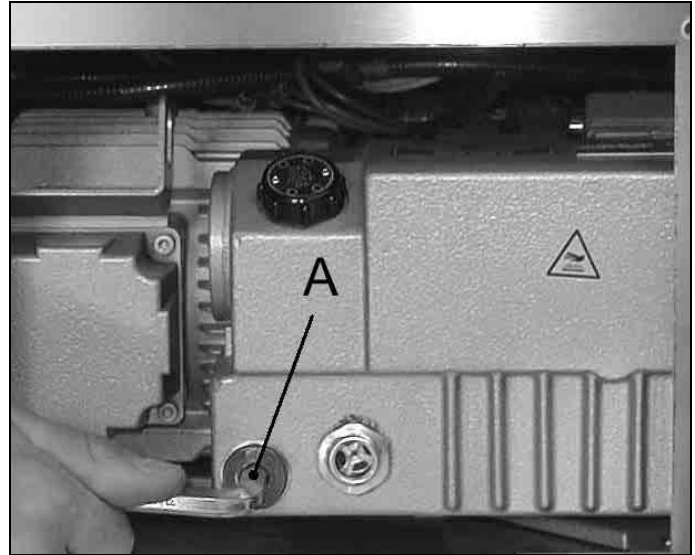

(B) OIL FILLING PLUG

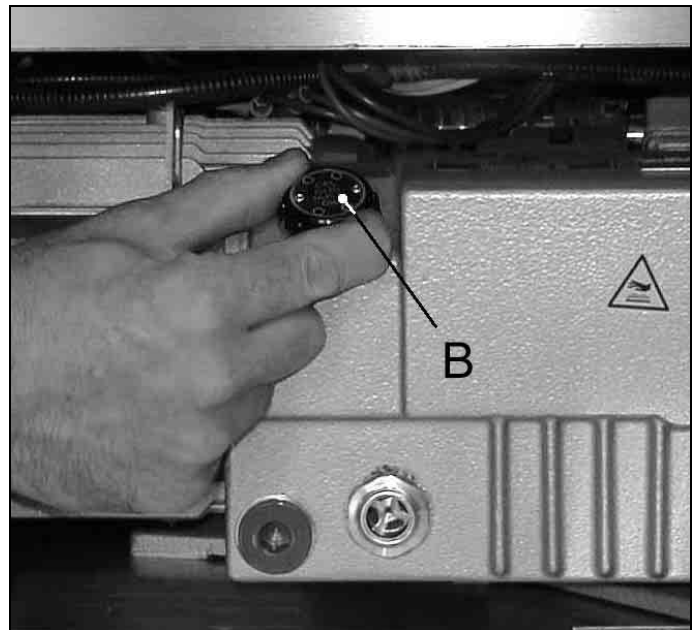

7.7. Wiring diagram

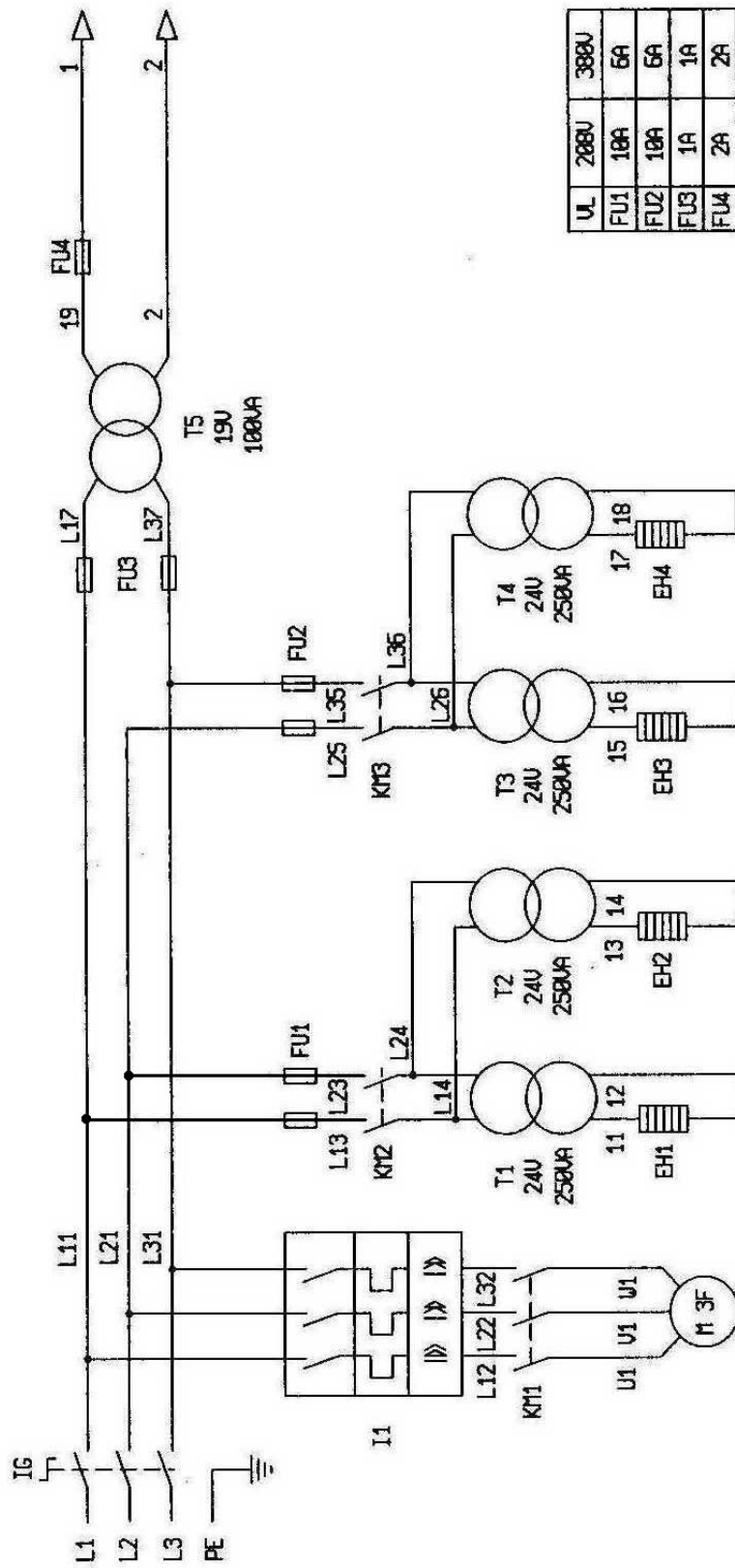

7.7. Electrical Schematic

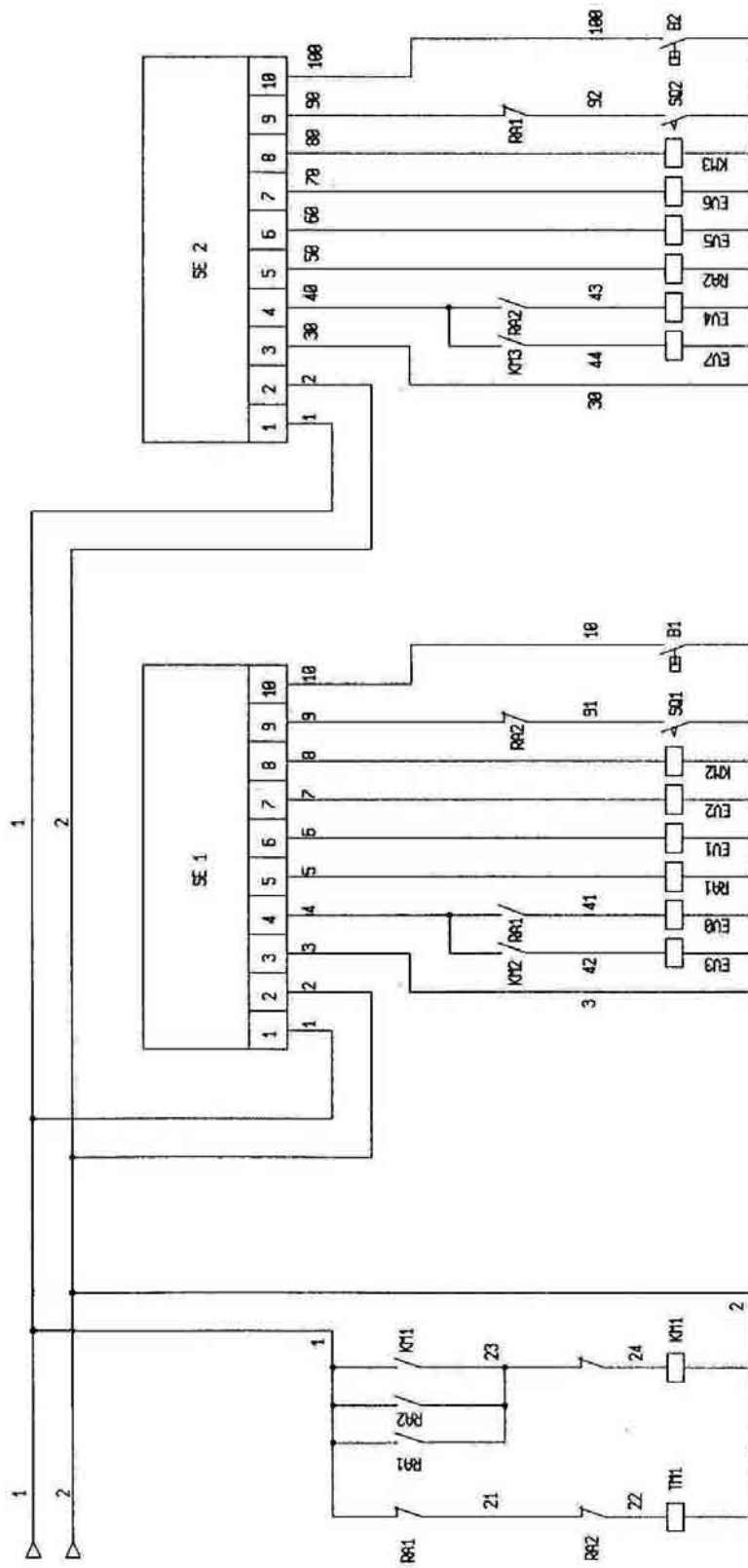

7.8. Key wiring diagram

<i>IG</i>	Main switch	<i>EH4</i>	Sealing blade heater 4
<i>I1</i>	Thermic protection for pump motor	<i>SE1</i>	Electronic board 1
<i>KM1</i>	Pump motor contactor	<i>SE2</i>	Electronic board 2
<i>KM2</i>	Sealing chamber contactor 1	<i>RA1</i>	Vacuum auxiliary relay 1
<i>KM3</i>	Sealing chamber contactor 2	<i>RA2</i>	Vacuum auxiliary relay 2
<i>M</i>	Vacuum pump motor	<i>TM1</i>	Pump stop timer
<i>FU1</i>	Sealing fuses 1	<i>SQ1</i>	Micro start 1
<i>FU2</i>	Sealing fuses 2	<i>SQ2</i>	Micro start 2
<i>FU3</i>	Auxiliary transformer primary fuse	<i>EV0</i>	Vacuum airvalve 1
<i>FU4</i>	Auxiliary transformer secondary fuse	<i>EV1</i>	Air re-immission airvalve 1
<i>T1</i>	Sealing bar transformer 1	<i>EV2</i>	Gas airvalve 1
<i>T2</i>	Sealing bar transformer 2	<i>EV3</i>	Sealing airvalve 1
<i>T3</i>	Sealing bar transformer 3	<i>EV4</i>	Vacuum airvalve 2
<i>T4</i>	Sealing bar transformer 4	<i>EV5</i>	Air re-immission airvalve 2
<i>T5</i>	Auxiliaries transformer	<i>EV6</i>	Gas airvalve 2
<i>EH1</i>	Sealing blade heater 1	<i>EV7</i>	Sealing airvalve 2
<i>EH2</i>	Sealing blade heater 2	<i>B1</i>	Gas pressure switch
<i>EH3</i>	Sealing blade heater 3	<i>B2</i>	Gas pressure switch 2

7.9. Pneumatic diagram

<i>CV</i>	Vacuum hood
<i>UG</i>	Gas nozzles
<i>BA</i>	Suction pipe union
<i>EV</i>	Gas airvalve
<i>PG</i>	Gas pressure switch
<i>BG</i>	Gas cylinder
<i>EA</i>	Air airvalve
<i>MP</i>	Pneumatic membrane
<i>ES</i>	Sealing valve
<i>PS</i>	Vacuum pump
<i>S</i>	Sensor

7.10. Spare parts

Sealing bar BS480001
Gasket GM590020 (2,7mt.x2)
Hood FM080071
Shock absorber FM640012
Shock absorber FM640012
Complete electronic board KR991037
60m3 pump FM730002
Vacuum airvalve FE140000
Sealing airvalve FE140010
50VA 208V transformer FE440712 / 50VA 380V
transformer FE440714
250VA 208V transformer FE440707 / 250VA 380V
transformer FE440701
Gas pressure FE470000

- 16 Sealing bar BS480001
- 17 Gasket GM590020 (2,7mt.x2)
- 18 Hood FM080071
- 19 Shock absorber FM640012
- 20 Shock absorber FM640012
- 21 Complete electronic board KR991037
- 22 60m3 pump FM730002
- 23 Vacuum airvalve FE140000
- 24 Sealing airvalve FE140010
- 25 50VA 208V transformer FE440712 / 50VA
- 380V transformer FE440714
- 26 250VA 208V transformer FE440707 / 250VA
- 380V transformer FE440701
- PG Gas pressure FE470000

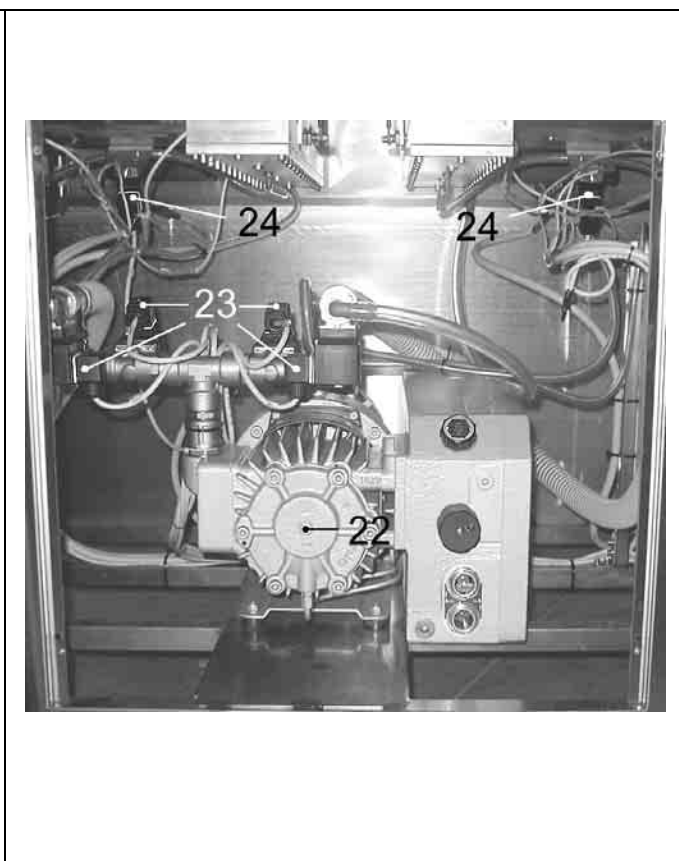
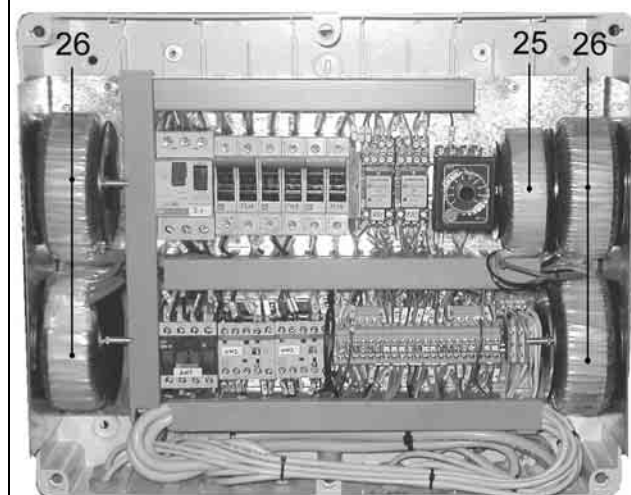
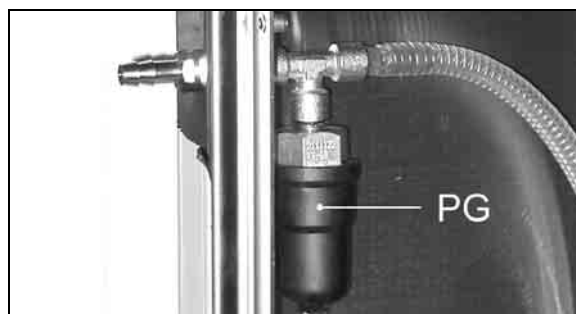
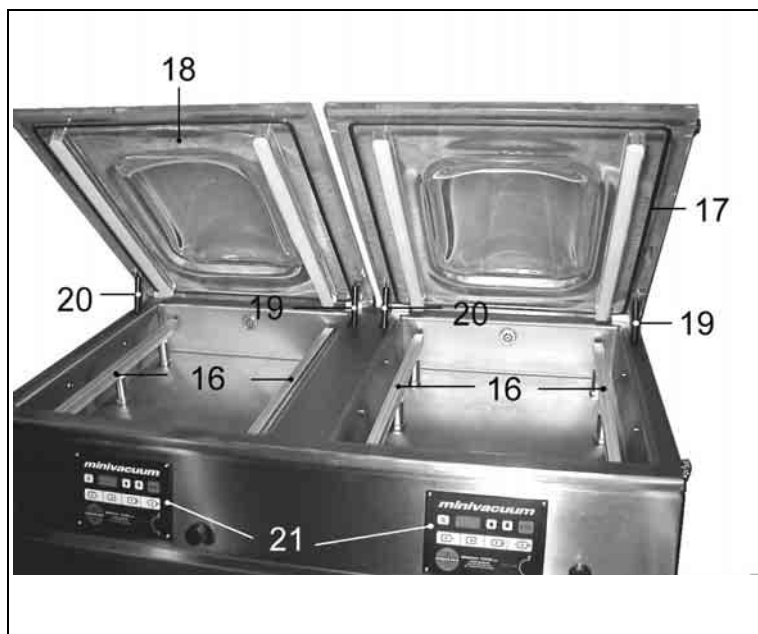

7.11. Disassembling, demolition and elimination of residuals



ATTENTION!

All operations about disassembling and demolition must be done by qualified personnel with mechanical and electrical expertise required to work in security conditions.

Proceed as follows:

- 1. disconnect machine from power mains*
- 2. disassemble components*
- 3. remove oil from the pump*

All wastes must be treated, eliminated or recycled according to their classification and to the procedures in force established by the laws in force in the country the equipment has been installed.

Minipack Limited Warranty Statement

Model and Serial Number:

Equipment manufactured by minipack-torre is warranted to be free of defects in parts and craftsmanship for a period of one (1) year from the date of installation, or 15 months from the invoice, whichever occurs first, minipack-america's exclusive obligation under this warranty is limited to repairing or, at its option, replacing any minipack-torre part that is determined by minipack-america to be defective. The warranty is for the original purchaser of new equipment.

Component subsystems manufactured by minipack-torre carry the warranty as stated herein. The warranty does not apply to subsystem component parts which are not manufactured by minipack-torre. Subsystem component parts not manufactured by minipack-torre shall be subject to any warranty of its manufacturer.

This warranty shall not apply to damage resulting from installation, modification, or repair by anyone other than a minipack-america authorized distributor/dealer. Nor shall it apply to any equipment which has been subject to accident, alterations, neglect, misuse or improper maintenance.

In the event of highly corrosive or high moisture applications, special protective coatings or stainless steel construction might be needed.

minipack-torre and minipack-america shall not be liable if minipack-torre equipment or components are used with accessory equipment not manufactured by minipack-torre.

Representations and/or warranties, by whomever made (even if made by minipack-america authorized distributors/dealers), which are inconsistent with the terms herein shall not constitute a term of the minipack-torre or minipack-america express warranty and shall not be binding on minipack-torre or minipack-america.

THE LIMITED WARRANTY SET FORTH ABOVE IS THE SOLE AND ENTIRE WARRANTY PERTAINING TO THE PRODUCT AND IS IN LIEU OF AND EXCLUDES ALL OTHER WARRANTIES OF ANY NATURE WHATSOEVER, WHETHER EXPRESSED, IMPLIED OR ARISING BY OPERATION OF LAW, INCLUDING, BUT NOT LIMITED TO ANY IMPLIED WARRANTIES OF MERCHANTABILITY OR FITNESS FOR A PARTICULAR PURPOSE. THIS WARRANTY DOES NOT COVER OR PROVIDE FOR THE REIMBURSEMENT OR PAYMENT OF INCIDENTAL OR CONSEQUENTIAL DAMAGES OF ANY TYPE, MANNER OR DEGREE, AND ANY LIABILITY BY MINIPACK-TORRE OR MINIPACK-AMERICA FOR SUCH INCIDENTAL OR CONSEQUENTIAL DAMAGES IS HEREBY DISCLAIMED. Some states do not allow this exclusion or limitation of warranties and/or damages, so the above limitations and/or exclusions might not be applicable to you. This warranty gives you specific legal rights, and you might also have other rights that vary from state to state.