



VACUUM PACKING MACHINE

# ***MV45L***

# ***MV48***

# ***MV50***



ENGLISH



DOC. N. FM111026  
REV. 02  
Ed: 11.2002

<b>Chapter 1. Foreword</b>	
1.1. Preface.....	8
1.2. Performances of packaging machine.....	8
1.3. Machine identification.....	8
1.4. Weight and dimensions of packed machine.....	8
1.5. Machine weight and dimensions.....	8
<b>Chapter 2. Machine installation</b>	
2.1. Transport and positioning.....	8
2.2. Environmental conditions.....	8
2.3. Installation diagram.....	8
2.4. Users.....	9
2.4.1. Electrical connections.....	9
2.4.2. Gas connections.....	9
<b>Chapter 3. Machine adjustment and setting up</b>	
3.1. Adjustment.....	9
<b>Chapter 4. Limits and conditions in the use of machine</b>	
4.1. Items not to be packed.....	10
<b>Chapter 5. Pouches features</b>	
5.1. Pouches to use.....	10
<b>Chapter 6. Safety standards</b>	
6.1 Warnings.....	11
<b>Chapter 7. Ordinary maintenance</b>	
7.1. Precautions for ordinary maintenance interventions.....	11
7.2. Cleaning of the sealing bar.....	11
7.3. Replacement of the Teflon and the sealing blade.....	11
7.4. Replacement of the cover gasket.....	11
7.5. Cleaning machine.....	11
7.6. Changing the oil and the pump filter.....	11
7.7. Wiring diagram.....	12
7.8. Pneumatic diagram .....	12
7.9. Disassembling, demolition and elimination of residuals.....	12
<b>Chapter 8. Guarantee</b>	
8.1. Certificate of guarantee.....	12
8.2. Guarantee conditions.....	12
EC declaration of conformity.....	37

# Chapter 1. Foreword

## 1.1. Preface

This manual has been drawn up in compliance with the UNI 10893 standard dated July 2000.

It is meant for all users in order to enable them to use the machine correctly. Keep it in a place which can be easily accessed in the proximity of the machine and which is known to all users.

This manual is an integral part of the machine for safety reasons.

We wish to specify the symbols in use here below in order to improve their understanding.



### **ATTENTION:**

**Accident prevention rules for the operator. This warning indicates the presence of dangers which can injure the person operating on the machine.**



### **WARNING:**

**It indicates the possibility of damaging the machine and/or its components.**

## 1.2. Performances of packaging machine

This machine represents what the modern technology of vacuum-packing may express at its best. It is flexible, easily programmable and cheap. It is intended to vacuum-pack foodstuffs by removing oxygen as well as any chemical and biological pollutant present in the environment. To attain the vacuum level you wish, just program the machine in order to remove almost all the air contained in the packet. Your product will preserve its organoleptic features, colour, taste, flavour and nutritive value for a long time.

## 1.3. Machine identification

In every communication with the Manufacturer, always mention the model and the serial number specified on the plate on the rear part of the machine.

## 1.4. Weight and dimensions of packed machine

<b>MV45L</b>	Width W = 770 mm	Length l = 860 mm	Height H = 1300 mm	Peso = 114Kg
<b>MV48</b>	Width W = 770 mm	Length l = 860 mm	Height H = 1300 mm	Peso = 180Kg
<b>MV50</b>	Width W = 770 mm	Length l = 860 mm	Height H = 1300 mm	Peso = 200Kg

## 1.5. Machine weight and dimensions

<b>MV45L</b>	Width W = 550 mm	Length l = 600 mm	Height H = 1350 mm	Peso = 101Kg
<b>MV48</b>	Width W = 600 mm	Length l = 760 mm	Height H = 1400 mm	Peso = 160Kg
<b>MV50</b>	Width W = 770 mm	Length l = 690 mm	Height H = 1400 mm	Peso = 185Kg

# Chapter 2. Machine installation

## 2.1. Transport and positioning

**When transporting and positioning the machine, it is recommended to handle it with great care!**

**Neither overturn nor tilt the machine! Oil might come out of the pump and damage the machine.**

### **LIFT UP THE PACKING AND MACHINE WITH A FORKLIFT.**

- Cut the strap (1) with scissors make sure you protect your eyes by wearing glasses.
- Remove the upper carton (2).
- Cut the strap (3) fastening the machine to the pallet.
- Lift the machine and place it on the working surface. Make sure the machine is placed in a proper environment without any inflammable and explosive materials or gas.
- Once the correct height is obtained, block the machine by means of the wheel brakes.

## 2.2. Environmental conditions

Working environmental conditions:

- Temperature from + 5°C to + 40°C
- Relative humidity from 30% to 90%, without condensation

The lighting of the operation room shall comply with the laws in force in the country where the machine is installed. However, it shall be uniform and provide for good visibility in order to safeguard the operator's safety and health.

**MACHINE SAFETY FACTOR = IP20**

**THE AERIAL NOISE MADE BY THE MACHINE IS LOWER THAN 70dB**

## 2.3. Installation diagram

I Electrical connections

H Gas connection

## Chapter 2. Machine installation

### 2.4. Users

#### 2.4.1. Electrical connections

**OBSERVE HEALTH AND SAFETY REGULATIONS!**  
**GROUNDING OF THE UNIT IS OBLIGATORY!**

Before executing electrical connections (13), make sure the mains voltage matches the one on the plate (14) on machine rear and that the earthing contact complies with the safety rules in force. In case of doubts about the mains voltage, contact the local public supply Company.

#### 2.4.2. Gas connection

Connect gas attachment (15), in case the machine is equipped with such a device, to the gas cylinder through the proper tube (T).

Pressure of gas plant has to be set on about 2 atm., bearing in mind the max. working pressure is 4 atm.

If the pressure is not correct, act on the knob of the pressure reducer (R).

**Use specific gas for food package in compliance with the rules in force about food additives in the country where the machine is used.**



**The oxygen percentage in the gas mixture shall not exceed 20%.**

## Chapter 3. Machine adjustment and setting up

### 3.1. Adjustment

1. Main switch
2. Control panel
3. Adjusting knob for air re-immission
4. Selection button
5. Display
6. Adjusting button
7. Adjusting button
8. Stop button
9. Led for vacuum and extra vacuum function
10. Led for gas function
11. Led for sealing function
12. Led for air re-immission function

#### FEATURES OF THE ELECTRONIC CARD

The machine has 9 selectable programs.

Each program is made of 4 changeable variables:

Variable	Field	Field Features
1. Vacuum	0 ÷ 99,9	Values expressed in %
2. Extra vacuum	0 ÷ 30	Values expressed in seconds
3. Gas	0 ÷ 99	Values expressed in % (never exceed 50%)
4. Welding	0 ÷ 4	Values expressed in seconds

All packaging machines are tested at works.

The parameters set at works generally prove to be fit for use.

#### PHASE 1 = START-UP

Switch 1 the main switch (1). As soon as the board has been switched on, display will show the software version, then the last program being executed (P1÷P9).

#### PHASE 2 = PROGRAMS SELECTION

To select the program number, just press the buttons (6) and (7).

#### PHASE 3 = VARIABLES PROGRAMMING

Press button (4) to enter scheduling of the program shown at the moment. By pressing again button (4), all parameters for the selected program will appear one after the other. Push buttons (6) and (7) to increase or decrease the value of the parameter shown. Parameters are stored when, while running a program, the number of the program itself will appear on the display.

##### 1) VACUUM

It is possible to set a value from 0 to 99,9%.

The recommended vacuum percentage is 99,9%.

Scheduling of vacuum parameter is signalled through LED (9).

##### 2) EXTRAVACUUM

You enter scheduling of such a parameter when going beyond value 99,9%. Extra vacuum parameter is shown on the display through letter "E"; its value is included between 0 and 30 seconds. During this time the pump keeps on extracting air from the hood after the machine has reached the adjusted vacuum level. This function is useful especially when packing porous products as it is quite difficult to extract air from them (for example: meat).

## Chapter 3. Machine adjustment and setting up

### 3) GAS

It is possible to set a value from 0 to 99,9%. Such a parameter cannot be higher than the vacuum one, otherwise you will obtain an opposite function. Scheduling of gas parameter is signalled through LED (10). If the gas LED (10) is flashing, it means the gas cylinder is not properly connected and machine will not start. Connect it properly.

**N.B.:** When scheduling a program "vac + gas", the minimum residual vacuum percentage soon after gas immission should be higher than 50%

**Example:** VAC 99%  
GAS 49%

Residual vacuum (99-49)= 50%

### 4) SEALING

It is possible to set a value from 0 to 4 seconds. For the first working cycles it is recommendable to set a sealing time of about 2,5 seconds and then lower it to prevent the teflon tape from burning. Scheduling of sealing time parameter is adjusted through LED (11).

#### PHASE 4 = EXECUTION

Place the pouch inside the hood and on the sealing bar in a way as linear as possible. Try to prevent the pouch from wrinkling. Wrinkles might negatively affect the hermetic seal formed by sealing.

Pouches shall be at least 2 cm beyond the sealing bar.

Lower the upper plexiglas cover.

The machine will start executing its working cycles.

After every working cycle, on the display will appear a number showing the total cycles being executed.

All set-up parameters are stored until they are modified.

**N.B.:** if you press the **STOP** button (8), the machine will immediately stop sucking and automatically start sealing the pouch. This function will be used to pack liquid and hot products which may start boiling during the vacuum cycle.

After you have closed the upper cover, the packaging cycle will start. It consists of 4 phases:

1. Suction phase during which all the air contained inside the bell and the bag is sucked.
2. Gas injection phase (if the machine is equipped with a gas plant).
3. Sealing phase during which the packet is sealed.
4. Air re-enter phase and subsequent opening of the cover.

The hood will reach its atmospheric pressure and the upper cover will open again.

Machine is ready for a new packing cycle.

#### ELECTRONIC BOARD FUNCTIONS

**OIL:** Every 12000 cycles, the note OIL appears on the display. Do check oil level and colour like mentioned at chapter 7.6. Set to 0 the function pressing buttons (6) and (7) at the same time.

**OFF:** When you read OFF on the display, it means that card is shutdown. Do get in contact with the assistance service.

## Chapter 4. Limits and conditions in the use of machine

### 4.1. Items not to be packed

It is absolutely forbidden to pack the following products which might permanently damage the machine and harm operator:



- Liquids of any type and density in fragile containers
- Inflammable materials
- Explosive materials
- Gas bottles under pressure or of any type
- Bulk or volatile powders (unless a filter is assembled on the pump)
- Any material and product which might in any way cause the user to be in a dangerous situation and damage the machine



## Chapter 5. Pouches features

### 5.1. Pouches to use

They may be of different thickness and shall be both airtight and gastight.

## Chapter 6. Safety standards

### 6.1. Warnings

		<p>Do not touch the sealing blade (16) immediately after sealing. <b>Danger of burns</b> due to hot blade.</p> <p>Do not touch the vacuum pump (23) just after a working cycle. <b>Possibility of burning</b> due to the high temperature the pump may reach.</p> <p><b>USE PROTECTION GLOVES!</b></p>
---	---	--

	<p>Do not seal if the sealing wire is broken. <b>Replace it immediately.</b></p> <p>In case of a power failure during a working cycle when the cover is closed, do not use any tool in order to force its opening. Wait for the power supply to be restored.</p>
---	--

	<p>Before any working cycle make sure that the closing hook (19) will not prevent the operator from closing the cover correctly. <b>Possibility of breaking the cover.</b></p>
---	--

## Chapter 7. Ordinary maintenance

### 7.1. Precautions for ordinary maintenance interventions

**BEFORE ANY ROUTINE MAINTENANCE SWITCH THE MACHINE OFF BY ACTING ON THE MAIN SWITCH AND REMOVE THE PLUG FROM THE MAINS SOCKET. DISCONNECT GAS PLANT.**

### 7.2. Cleaning of the sealing bar

Use a dry cloth to remove any film residue on the sealing bar (16). Carry out this operation just after any sealing cycle. Residues are still hot and may be easily removed.

### 7.3. Replacement of the Teflon and the sealing blade

Before replacing teflon and the sealing blade wait for the machine to be properly cooled.

- Remove the sealing bar (16) from its seat.
- Remove the teflon adhesive tape.
- Unscrew the screws fastening the blades to each end of the sealing bar.
- Tighten the new blades. Make sure they are tight enough before blocking them.
- Use the teflon adhesive tape to cover the sealing blades.
- Place the sealing bar into its seat.

### 7.4. Replacement of the cover gasket

When the cover gasket (17) is worn out, replace it. This will improve the efficiency of the machine and increase its speed rate. Replacement is very easy. After having removed the gasket which has worn out, clean its seat and insert the new gasket in a linear way. Make sure its ends are joined. Leave no opening which might prevent the product from being properly vacuum-packed.

### 7.5. Cleaning machine

Use a normal wet cloth to clean the plexiglas cover (18).

Never use detergents or solvents which might damage the hood and reduce its transparency as well as its resistance.

Use normal detergents for stainless steel to clean the case and the internal tank.

### 7.6. Changing the oil and the pump filter

Follow the instructions you can find on the pump manual in order to change the oil and the vacuum pump filter.

However, oils of the VC type shall be used in compliance with the DIN 51506 standards.

It is recommended to use original BUSCH oils of the VM series in compliance with the DIN standards.

	<p><b>The oil you have replaced must be eliminated according to the procedures established by the laws in force in the country the equipment has been installed.</b></p>
---	--

(20) **PLUG FOR OIL DISCHARGE** (to completely replace old oil)

(21) **OIL FILLING PLUG**

(22) **VISUAL LEVEL**

## Chapter 7. Ordinary maintenance

### 7.7. Wiring diagram

#### (Single phase version)

Q1	Main switch	QM2	Blade heater contactor	T2	Auxiliary transformer
FU1	Line fuse	QV1	Air re-immission valve	R1	Blade heater
FU2	Pump fuse	QV2	Gas injection airvalve	R2	Blade heater
FU3	Blade fuse	QV3	Sealing airvalve	B0	Limit switch
FU4	Auxiliary transformer fuse	M1	Pump motor	B1	Gas pressure switch
QM1	Motor contactor	T1/3	Blade transformer	SE	Electronic board

#### (Three phase version)

Q1	Main switch	QV2	Gas injection airvalve	R2	Blade heater
FU1	Blade fuse	QV3	Sealing airvalve	B0	Limit switch
FU2	Auxiliary transformer fuse	M1	Pump motor	B1	Gas pressure switch
QM1	Motor contactor	T1/3	Blade transformer	SE	Electronic board
QM2	Blade heater contactor	T2	Auxiliary transformer	I1	Automatic switch
QV1	Air re-immission valve	R1	Blade heater		

### 7.8. Pneumatic diagram

CV	Vacuum hood	QV2	Gas injection airvalve	MP	Pneumatic membrane
UG	Gas nozzles	QV3	Sealing airvalve	M1	Vacuum pump motor
BA	Suction pipe union	B1	Gas pressure switch	PV	Vacuum pump
QV1	Air re-immission valve	BG	Gas cylinder	S	Sensor

### 7.9. Disassembling, demolition and elimination of residuals



#### **ATTENTION!**

All operations about disassembling and demolition must be done by qualified personnel with mechanical and electrical expertise required to work in security conditions.

Proceed as follows:

1. disconnect machine from power mains
2. disassemble components
3. remove oil from the pump

All wastes must be treated, eliminated or recycled according to their classification and to the procedures in force established by the laws in force in the country the equipment has been installed.

## Chapter 8. Guarantee

### 8.1. Certificate of guarantee

The guarantee runs for 12 months after the installation date under the conditions set forth on the instruction manual. Fill in the card with all data requested tear out along the perforations and send in.

### 8.2. Guarantee conditions

The guarantee runs for 12 months and goes into force on the installation date of the machine. The guarantee covers free replacement or repair of any parts due to defects arising from faulty material. The repairs or replacement are usually carried out at the manufacturer's, with transport or workmanship at buyer's charge. If the repair or replacement is carried out at the buyer's place, he shall bear the travelling, transfer and workmanship charges. Work under guarantee can be carried out exclusively by the manufacturer or by the authorized dealer. In order to be entitled to repairs under the guarantee, the faulty part must be sent for repair or replacement to the manufacturer or his authorized dealer. The return of such repaired or replaced part will be considered to be the performance of the guarantee. The guarantee is voided:

1. in case of failure to mail the CERTIFICATE OF GUARANTEE, duly filled in and signed, within 20 days after the date of purchase.
2. in case of inappropriate installation, power supply, misuse and mishandling by unauthorized persons.
3. in case of changes made to the machine without prior agreement in writing by the manufacturers.
4. if the machine is no longer the property of the first buyer.

**MINIPACK-TORRE S.p.A. are legally entitled to decline any responsibility for damage to persons or things in case of inappropriate installation or connection to the power mains or omission of connection to earth or in case of any mishandling of the machine.**

**The manufacturers undertake to carry out any variations and changes made necessary by technical and operating requirements.**



**DICHIARAZIONE CE DI CONFORMITA'  
EC DECLARATION OF CONFORMITY  
EG KONFORMITÄTSERKLÄRUNG  
DECLARATION CE DE CONFORMITE'  
DECLARACION CE DE CONFORMIDAD  
ÖVERENSTÄMMELSEFÖRKLARING EC**

Noi:  
We:  
Wir:  
Nous:  
Nosotros:  
Vi:

**MINIPACK-TORRE S.p.A.  
Via Provinciale, 54  
24044 DALMINE (BG)**

**dichiaro sotto la nostra esclusiva responsabilità che il prodotto  
declare under our responsibility that the product  
erklären unter unserer ausschließlichen Verantwortung daß, das in dieser Erklärung genannte Produkt  
déclarons sous notre exclusive responsabilité que le produit  
declaramos bado la nuestra esclusiva responsabilidad que el producto  
förklarar under eget ansvar, att produkten**

macchina confezionatrice sottovuoto tipo:  
vacuum packing machine model:  
Vakuumaschine Typ:  
machine confectionneuse sous-vide modèle:  
maquina confeccionadora tipo:  
vakuumförpackningsmaskin typ:

- MV45L**  
 **MV48**  
 **MV50**

N°

**è conforme a quanto prescritto dalle seguenti direttive e successive modifiche:  
is in conformity with provision of following directives and their modifications:  
ist im vebereinstimmung mit den Sicherheitszielen der Bestimmungen und Zuckünftige warianten:  
est en conformité avec les normatives prevues par les suivantes directives et successifs modifications:  
es conforme a cuanto previsto de la directiva y sucesives modificaciones:  
är överensstämmande med föreskrifterna i följande direktiv och dess därpå följande ändringar:**

**98/37/CE  
89/336/CEE  
73/23/CEE**

**E inoltre dichiariamo che sono state applicate le seguenti norme armonizzate:  
And furthermore we declare that the following rules have been applied:  
Und ausserden, wir bestaetigen dass, die folgenden bestimmungen angewandt sind:  
Et de plus nous declarons que les normes suivantes ont été appliques:  
Y además declaramos que han sido aplicadas las siguientes normas armonizadas:  
Dessutom förklarar vi, att följande harmoniserade normer har använts:**

**EN 292-1  
EN 292-2  
EN 60335-1  
EN 60204-1**

Dalmine, 15/02/1999

TORRE ing. FRANCESCO

  
Consigliere Delegato  
Managing Director  
Geschäftsführer  
Conseiller Délégué  
Consedero Delegato  
Verkställande Direktör

1.3.

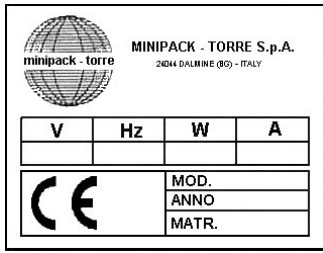

1.4.

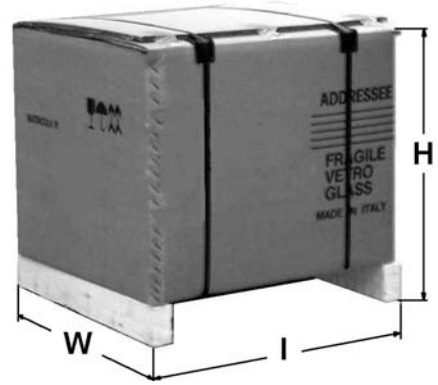

1.5.



2.1.

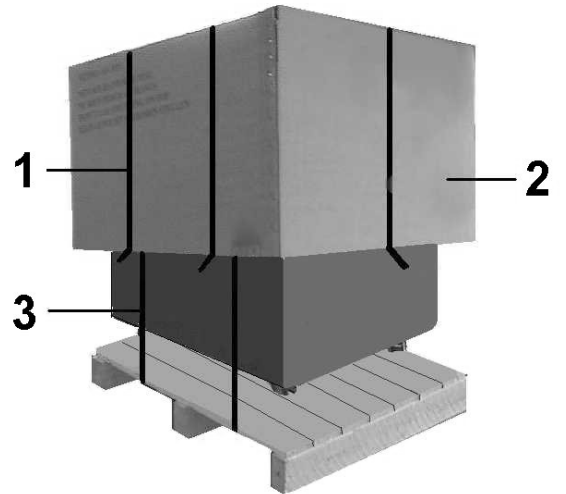

2.3.

**MV45L**

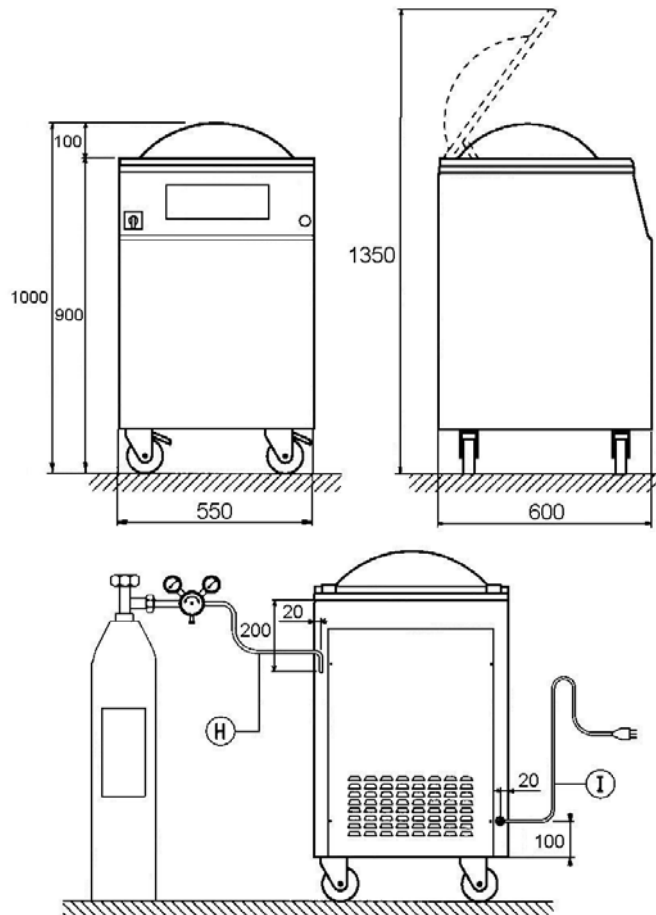

2.3.

MV48

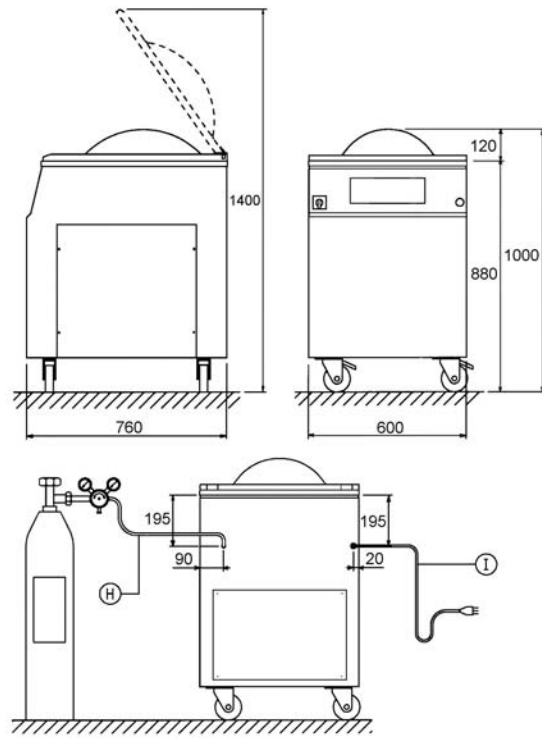

2.3.

MV50

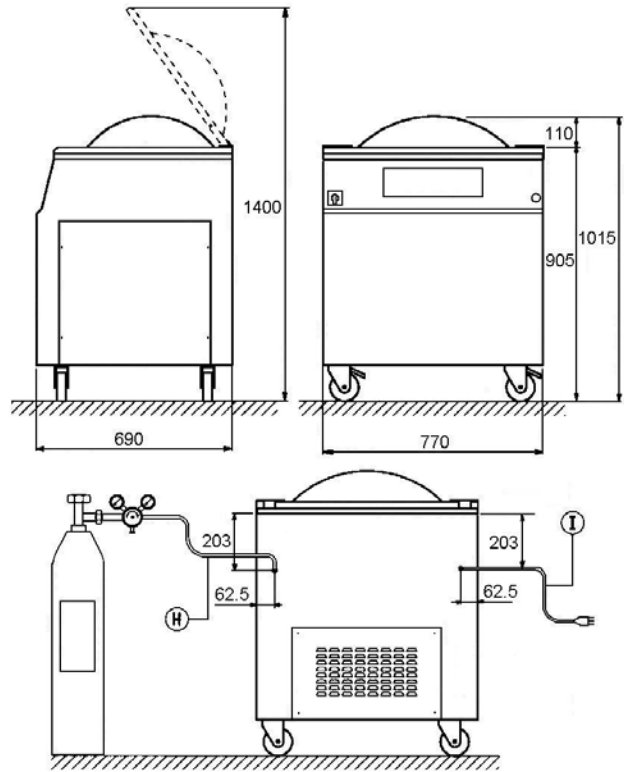

2.4.1. MV45L



2.4.1. MV48 / MV50



2.4.2.

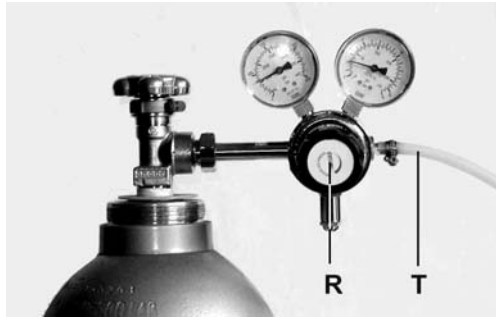

3.1.

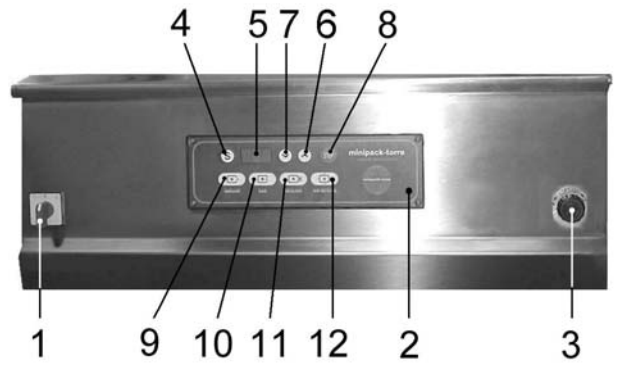

6.1.

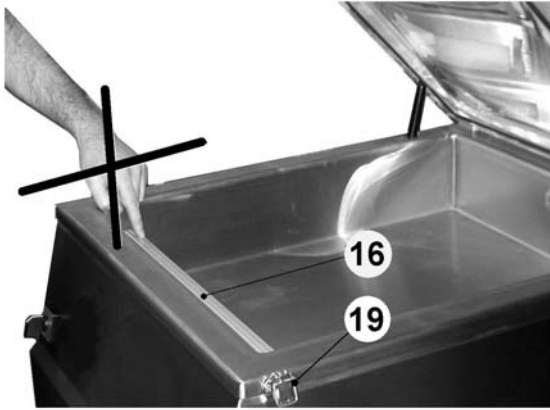

6.1.

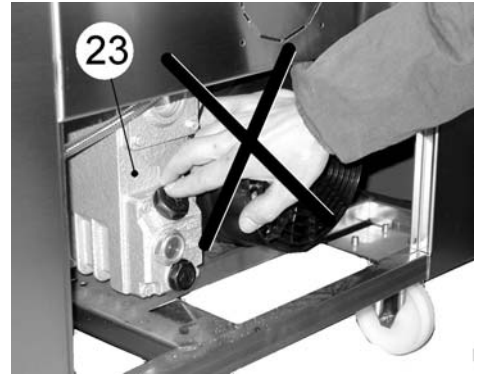

7.2.



7.3.



7.4.



7.5.

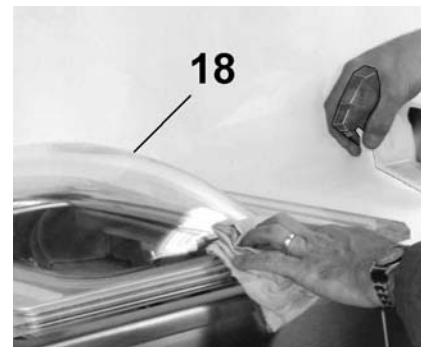

7.6. MV45L

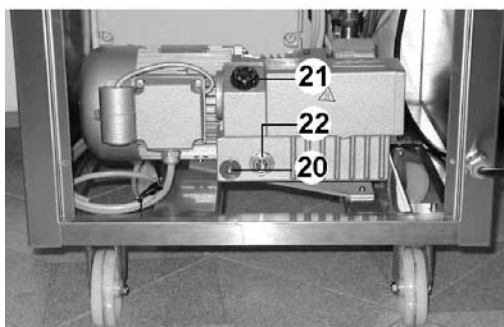

7.6. MV48 / MV50

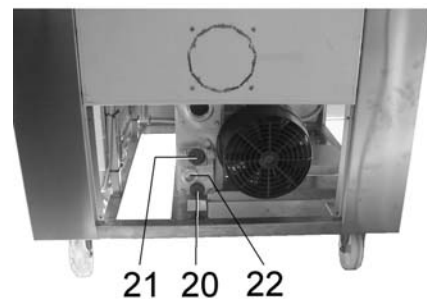

7.7. (Versione monofase/single phase version)

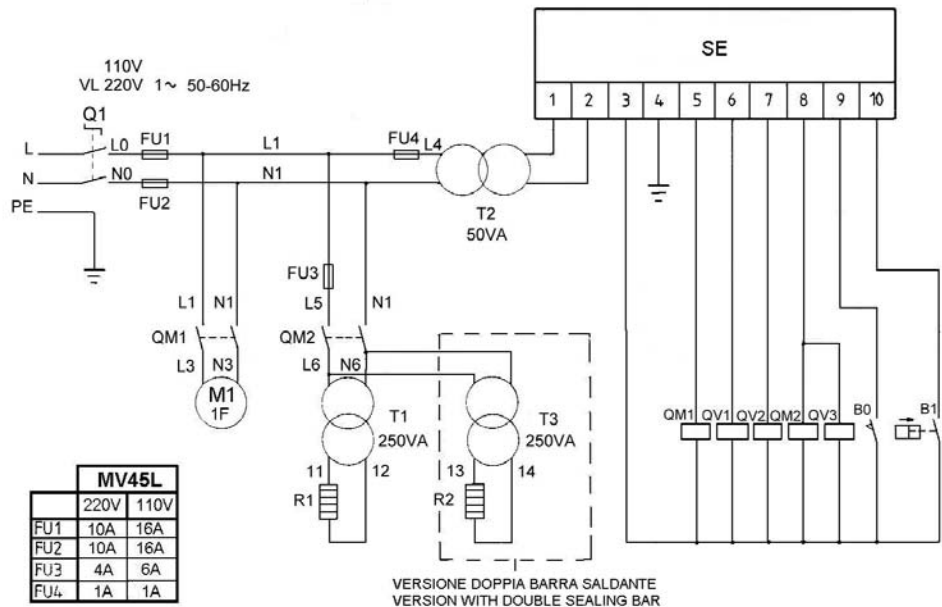

7.7. (Versione trifase/three phase version)

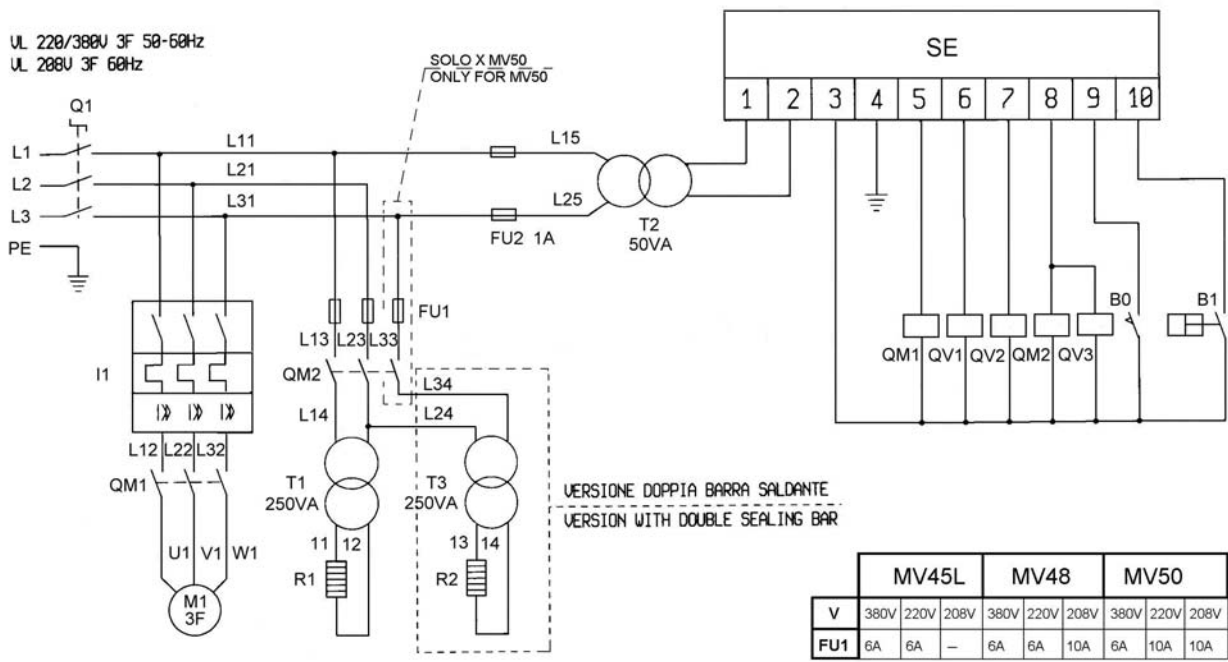

7.8.

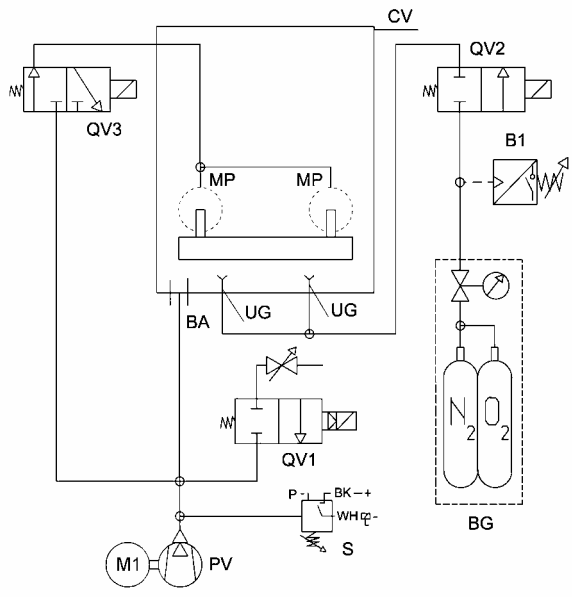

(I) Tipo  
(GB) Type  
(D) Typ  
(F) Type  
(E) Tipo  
(SVE) Typ

(I) Matricola  
(GB) Serial n°  
(D) Kennnummer  
(F) No. de série  
(E) No. de matrícula  
(SVE) Registreringsnummer

(I) Collaudo  
(GB) Test n°  
(D) Abnahmeprüfung  
(F) Essai  
(E) Ensayo  
(SVE) Besiktning

(I) Data di acquisto  
(GB) Date of purchase  
(D) Einkaufdatum  
(F) Date d'achat  
(E) Fecha de compra  
(SVE) Inköpsdatum

(I) Tipo  
(GB) Type  
(D) Typ  
(F) Type  
(E) Tipo  
(SVE) Typ

(I) Matricola  
(GB) Serial n°  
(D) Kennnummer  
(F) No. de série  
(E) No. de matrícula  
(SVE) Registreringsnummer

(I) Collaudo  
(GB) Test n°  
(D) Abnahmeprüfung  
(F) Essai  
(E) Ensayo  
(SVE) Besiktning

CERTIFICATO DI GARANZIA  
CERTIFICATE OF GUARANTEE  
GARANTIESCHEIN  
BULLETIN DE GARANTIE  
CERTIFICADO DE GARANTIA  
GARANTIINTYG

Data e timbro rivenditore  
Date and dealer's stamp  
Datum und stempel des verkaufers  
Date et timbre du revendeur  
Fecha y timbre del revendedor  
Datum och återförsäljarens stämpel

(I) Indirizzo acquirente  
(GB) Customer address  
(D) Adresse des Abnehmers  
(F) Adresse de l'acheteur  
(E) Dirección del comprador  
(SVE) Köparens adress

(I) Data di acquisto  
(GB) Date of purchase  
(D) Einkaufdatum  
(F) Date d'achat  
(E) Fecha de compra  
(SVE) Inköpsdatum

**Minipack-torre S.p.A.**

Via Provinciale, 54 - 24044 DALMINE (BG) - ITALY  
Tel. (035) 563525 – Fax (035) 564945  
E-mail: [info@minipack-torre.it](mailto:info@minipack-torre.it)  
Internet: [www.minipack-torre.it](http://www.minipack-torre.it)



Spett.le

**minipack-torre S.p.A.**

Via Provinciale, 54  
24044 DALMINE (BG)  
ITALY

MADE IN ITALY