

Patty-O-Matic, Inc.[®]
THE WORLD'S FINEST FOOD MACHINES

Model 330A

Owner's Manual

Revised May 2006



Route 547 P.O. Box 404 Farmingdale NJ, 07727

Tel: (732) 938-2757 Fax: (732) 938-5809

Toll Free in USA: 877-938-5244



Congratulations on the purchase of your new Model 330A Patty Molding Machine from Patty-O-Matic, Inc! The Model 330A will form, interleave paper between, and perfectly stack food patties. This machine is designed for easy operation and cleaning. Please become familiar with this manual and your machine will give you years of service.

The Model 330A is shipped to you in at least two cartons which contain the patty machine, feed tray, mold plate guard, parts box, receiving table, and this manual. If you purchased your machine with any other accessories, such as a mobile table or patty paper, these items may be in a separate carton. The parts box that comes with the machine should include a bottle of machine lubricant, a speed driver, samples of patty paper, and a spare parts kit.

Your machine is equipped with two interlocks. One is located on the front of the machine and one is located on the top of the machine. The Mold Plate Guard must be installed on the machine to engage the interlock on the front of the machine and the Feed Tray including the Guard must be installed on top of the Hopper to engage the interlock on top of the machine.

Installing the Mold Plate Guard

Loosen Guard Knobs on the hopper and place Mold Plate Guard under the fender washers located under the knobs. Tighten down on Guard Knobs. To Activate the interlock switch, slide push rod against the plunger, inside the keylatch, and turn rod to the right. This will lock the push rod in place and activate your interlock switch.

Installing the Feed Tray

Place stainless steel tube of feed tray over the hopper. This will push down on the safety interlock Tower located on the top of the Machine.

DO NOT ATTEMPT TO RUN THIS MACHINE WITHOUT THE FEED TRAY AND THE MOLD PLATE GUARD IN THEIR PLACE!! FAILURE TO DO SO COULD RESULT IN SERIOUS BODILY INJURIES!!

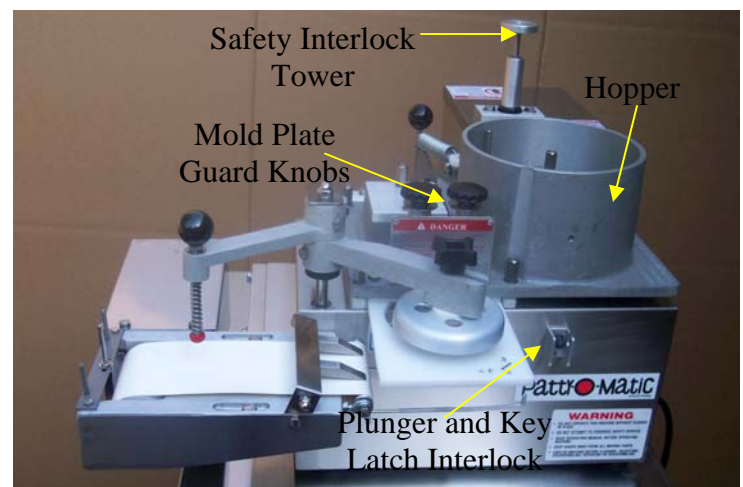

Please become familiar with some of the parts of your machine prior to operation.

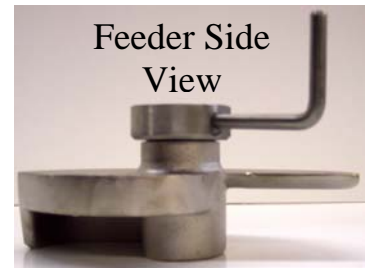
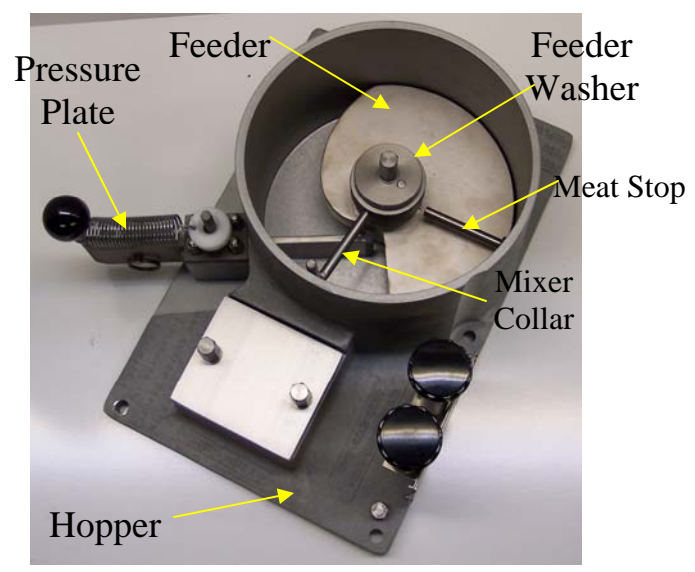

Mold Plate Assembly Side View



Mold Plate Assembly Underside View

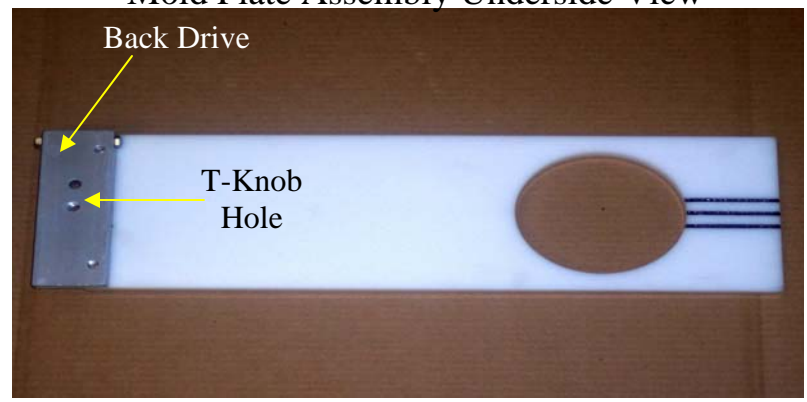

Ring Pin Pressure Plate



Knock Out Cup Assembly

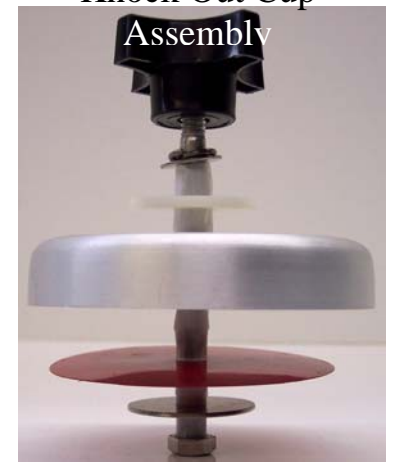

Feed Tray Guard











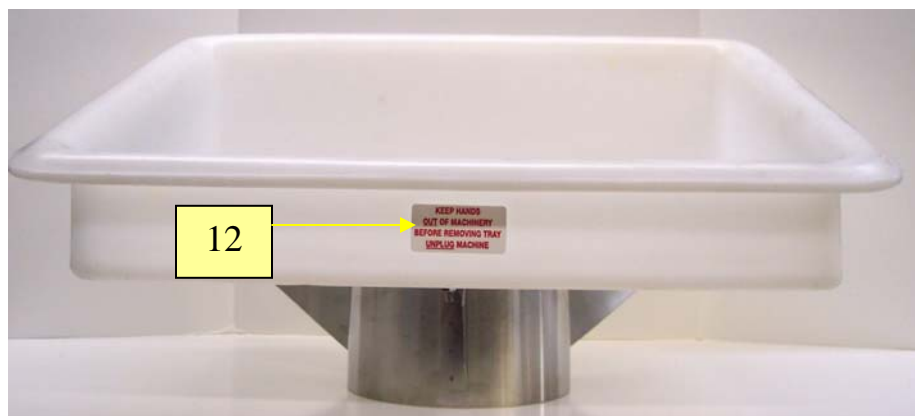
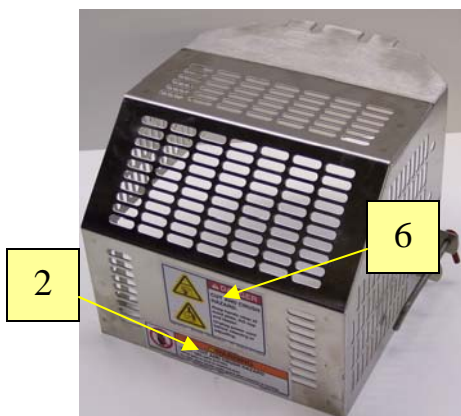
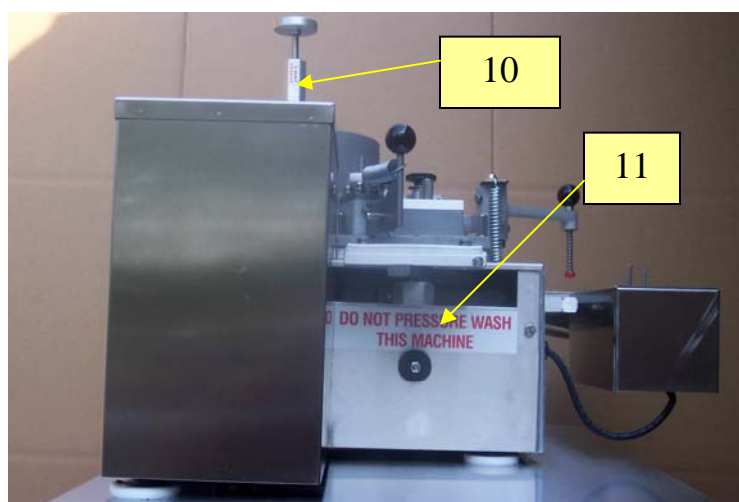
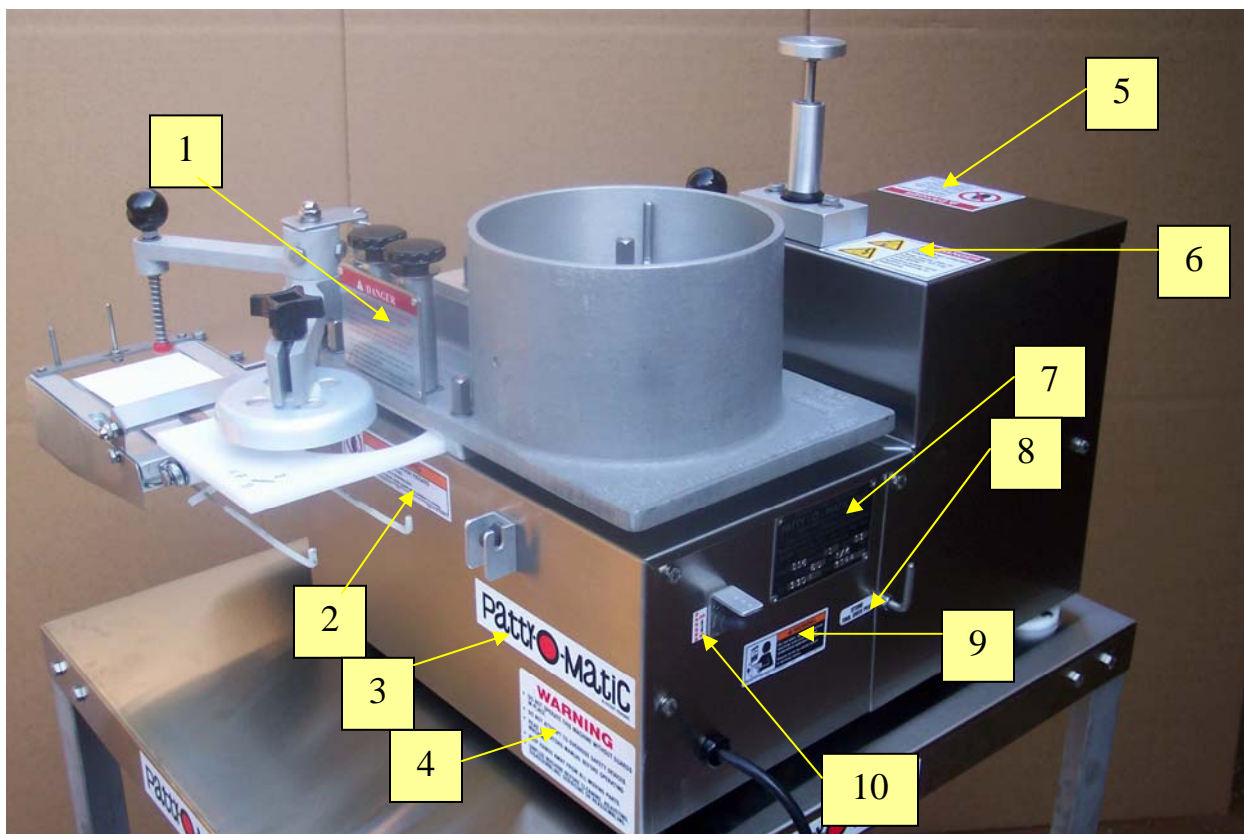

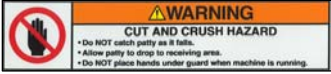

Mold Plate Guard

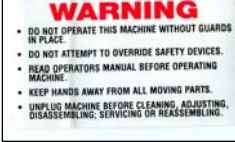

Feed Tray Guard and Mold Plate Guard are installed for your safety. Do not tamper with them in any way!

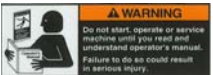
Proper Label Location for a Model 330A



<u>Item #</u>	<u>Description</u>		<u>Part #</u>
1.	Danger Tag		514-09
2.	Warning Orange		514-02
3.	Patty-O-Matic		514-08
4.	Warning		514-06
5.	Danger Label 1		514-03
6.	Danger Label 2		514-00
7.	Serial Tag		514-15
8.	Store Tool		514-14
9.	Warning Manual		514-01
10.	Danger on/off		514-05
11.	Do Not Pressure Wash		514-04
12.	Keep Hands		514-07

Proper Procedure for Operating a Model 330A

When the Model 330A is fully assembled with all guards secured in their proper place, put product in the Feed Tray. Push the product through the holes in the Feed Tray Guard into the hopper opening. **DO NOT PUT HANDS OR FINGERS, OR FOREIGN OBJECTS, SUCH AS STOMPERS OR PLUNGERS INTO THE HOPPER. THERE ARE NO STOMPERS OR PLUNGERS NEEDED WHEN USING THIS UNIT, THEREFORE NONE ARE SUPPLIED.** After you allow product to drop into hopper turn the machine on by moving the On/Off switch down towards the on position. The machine may need to cycle a few times to prime the machine with product. As patties are being formed continue to push product through the holes and under the Feed Tray Guard. Patty paper may be added to the machine as needed. The machine can hold up to 1 inch of paper at a time.

As the Mold Plate moves back and forth to form patties, a thin coating of product may accumulate over its surface. This coating may also accumulate on the edges of the Knock Out Cup or on the front of the hopper and spacer plate. This accumulation does occur on all molding machines. It is nothing to be concerned with. There are certain machine settings that may lessen this accumulation.

Setting the Ring Pin Pressure Plate for your Patty Size

The Purpose of the Pressure Plate is to entrap the amount of product necessary to form your patty. This part is also used in controlling the firmness of your patty. With the Pressure Plate set correctly you will in turn have:

- less leakage, oozing, and coating of parts
- less kneading of your product
- and less strain on your machine.

 If your patty weight is 8 ounces, keep the ring pin in the storage hole as described in the picture. This will allow the Pressure Plate to move all the way into the hopper and stop into the welded stud which is the maximum setting.

If your patty is 4 ounces remove the ring pin from the storage hole and place it in the 4 ounce hole.

If you patty weight is to be 6 ounces, place the ring pin in the 6 ounce hole.

If you would like to have a tightly packed patty, move the ring pin to a higher than recommended setting for that particular weight.

THESE ARE ONLY RECOMMENDED SETTINGS. A VARIETY OF CIRCUMSTANCES MAY CALL FOR YOU TO INSERT THE RING PIN IN A DIFFERENT LOCATION.

- | |
|---|
| 1 - Ring Pin in storage hole
2 - 2 ounce hole
3 - 3 ounce hole
4 - 4 ounce hole
5 - 5 ounce hole
6 - 6 ounce hole
7 - 7 ounce hole
8 - 8 ounce welded stop |
|---|

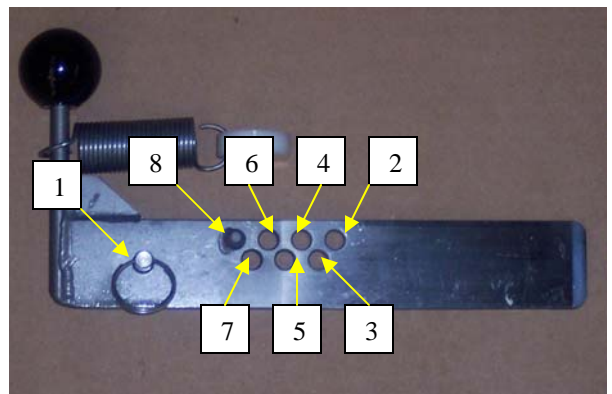

Changing Your Machine's Mold Plate

Always disconnect the machine from its power source before attempting to change any of the machines component parts.

First remove the T-Knob from the Back Drive of the Mold Plate, then pull the Mold Plate out from the rear of the machine. If you prefer, remove the Mold Plate from the machine without removing the T-Knob from the Back Drive. Simply unhook Connecting Arm from the T-Knob and slide the Mold Plate from the rear of the machine.

When changing the Mold Plate always use the corresponding Spacer Plate. The thickness fraction stamped on the Spacer Plate should match the fraction stamped on the front right corner of the Mold Plate. For example: if your Mold Plate is stamped "4F 1/2" then the Spacer Plate should be stamped "1/2". The Spacer Plate is retained by the X-Bolt. The X-Bolt is threaded into the Hopper. Turn the X-Bolt counter clockwise enough to remove the Spacer Plate. There is no need to remove the X-Bolt from the Hopper. After putting the new Mold Plate and corresponding Spacer Plate into the machine, turn the X-Bolt into the hole located on the front of the Spacer Plate just enough to hold the plate in place. DO NOT over tighten X-bolt into hopper. This may cause scoring of the Mold Plate or other damages to the machine.

Mold Plate and Connecting Arm Rear View

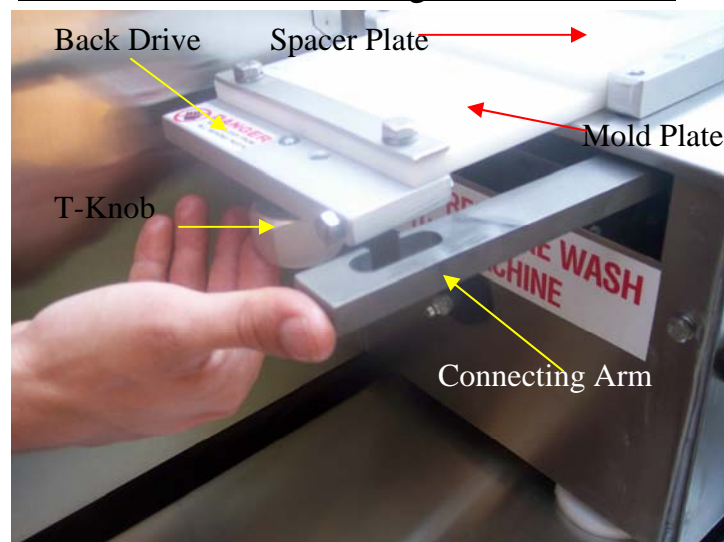

Hopper Front View

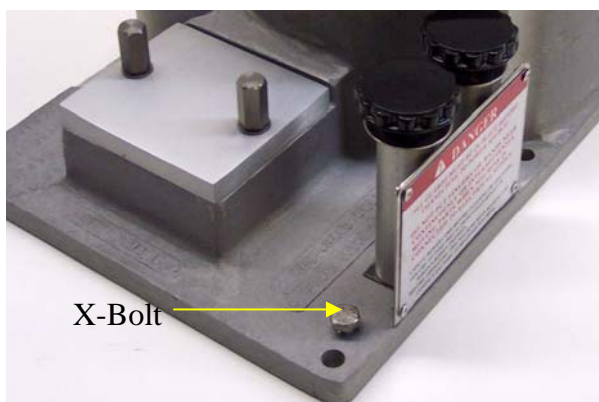

Spacer Plate Top View

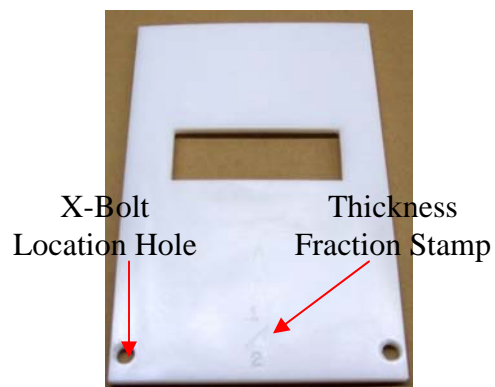

Proper Disassembly for Cleaning
Your Model 330A:
Always Unplug Machine From its
Electrical Source Before Cleaning

- Remove Feed Tray by lifting it off the Hopper, and Mold Plate Guard by loosening the Mold Plate Guard Knobs.

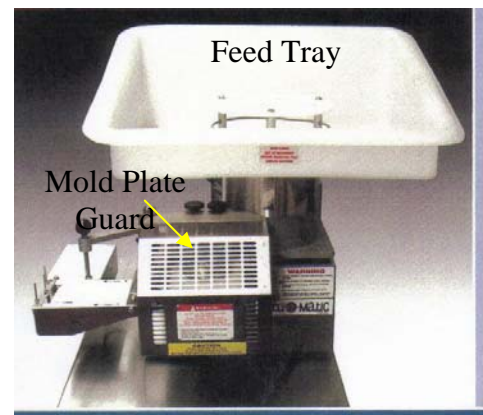

- Remove Pressure Plate by detaching spring and sliding Pressure Plate from inside of the Hopper. Remove feeder by unscrewing bolt using speed driver provided. Remove Feeder Washer by lifting it off the Feeder and lift Feeder from the inside of the hopper.

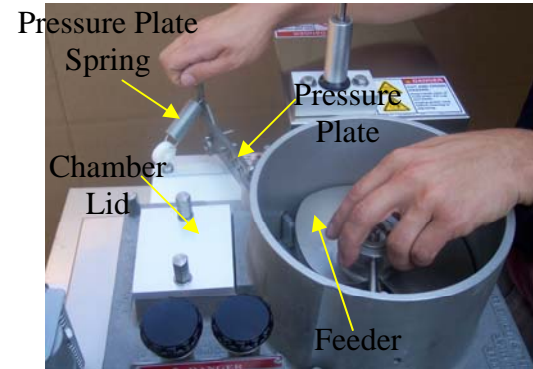

- Remove the four Hopper Bolts using the speed driver provided. The two bolts on the chamber lid may be removed as well for additional cleaning.

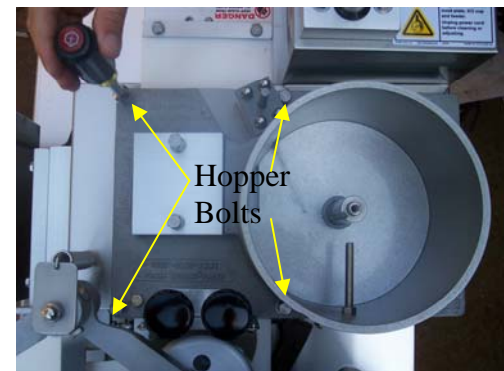

- Remove Hopper by lifting it off the Main Shaft of the Machine.

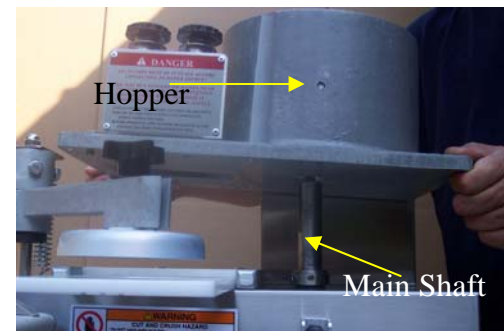

- After the Hopper is removed from the machine, remove spacer plate from the top of the mold plate. *Note--Occasionally the spacer plate sticks to the bottom of the Hopper.

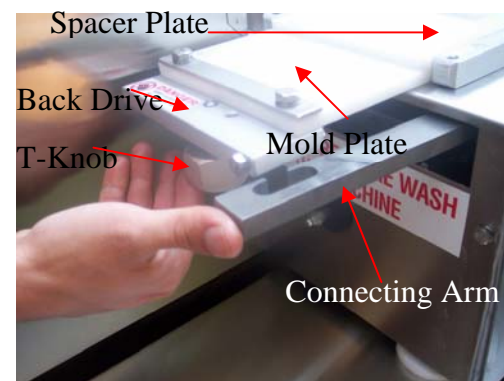

- Remove Knock Out Cup By loosening the Knock Out Knob while holding the other end of the bolt with the speed driver provided with the machine.

- All of the parts that were removed from the machine can now be washed and sanitized thoroughly. USDA recommends the sanitizing solution should be 50 parts per million, but no more than 200 parts per million. The machine itself should be cleaned and sanitized by hand. Allow the machine and parts to air dry.

This Machine Should Not be Hosed Down or Pressure Washed For Cleaning!

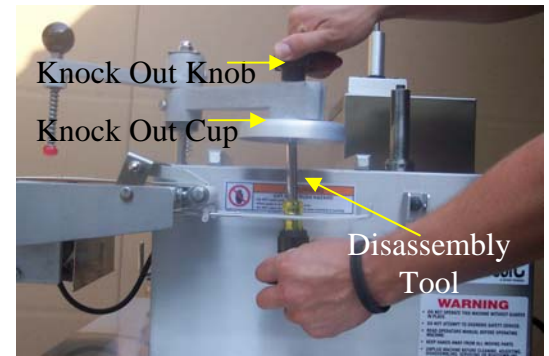

***To Re-Assemble the Machine reverse the above procedure. Hopper bolts should only be hand tightened with the speed driver provided.**

***The Knock Out Cup Should be installed on the Machine after all other parts are in place. The Mold Plate should be all the way forward and the Knock Out Arm should be in the down position for the cup to align with the mold plate properly.**

Installing Patty Paper on Interleaver:

Place a stack of Paper no thicker than one inch under the Pressure Foot. Slide hole in the stack of paper over center pin on interleaver. This can be accomplished without stopping the machines movement.

***Placing more than one inch of paper on center pin may cause improper paper feeding.**

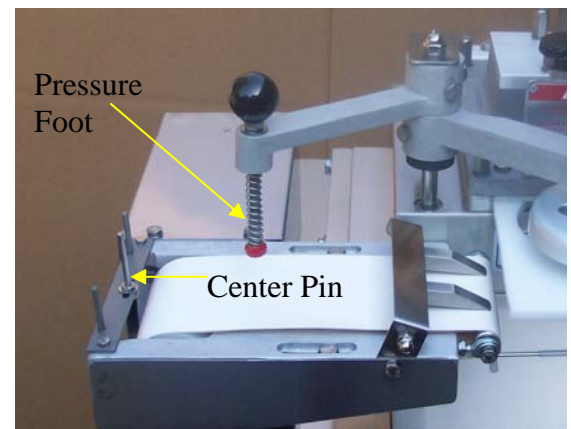

Patty-O-Matic Inc. offers the highest quality patty paper, machine lubricant, and machine grease. Please contact the factory for information on these products.

Toll Free in the U.S.A. 877-938-5244

Outside the U.S.A. 732-938-2757

P.O. Box 404 Farmingdale, NJ 07727

Points of Daily Lubrication For Your Model 330A:

10

Always Unplug Machine and use Food Approved Oil and Grease!

The Following Parts should be lubricated daily to ensure proper machine maintenance

- Pressure Foot should be lifted up and oiled. Hold the Ball knob and lift up. Place a few drops of oil on the pressure foot shaft.

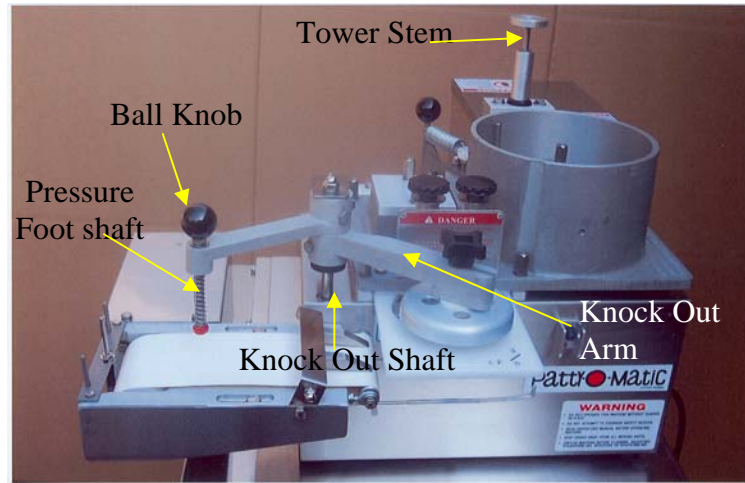

- Knock Out Shaft should be oiled when the Knock Out Arm is in the up position. The picture shown displays the Arm in the up position.

- Tower Stem should be oiled when the Feed Tray is removed as shown.

- Rod End Bearings should be oiled with a few drops of oil. There are two Rod End Bearings to be oiled. Do not allow oil to drip onto the Conveyor Belt.

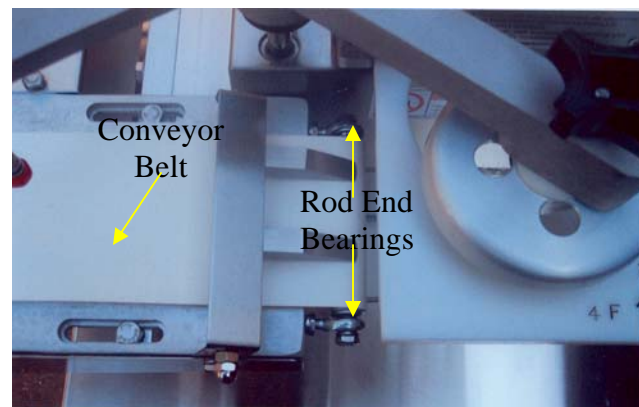

- Main Shaft should be oiled when the machine is disassembled as shown in this picture. Be sure to oil the bottom by the machine cabinet.

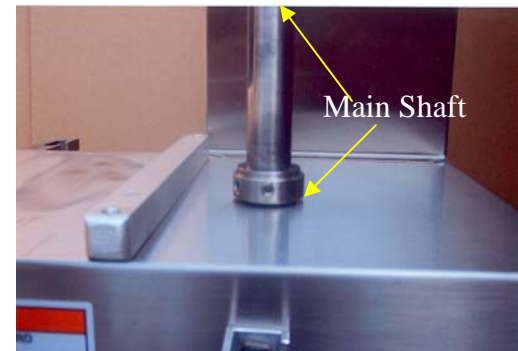

- The inside of the machine can be oiled through the Rear Inspection Opening. By spraying some oil here you will be oiling the inside components.

- The Grease Fitting in the back of the machine should be greased once every two weeks. 3 or 4 shots of grease are recommended.

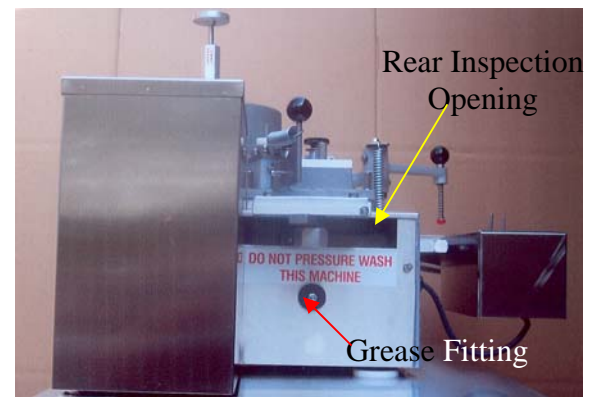

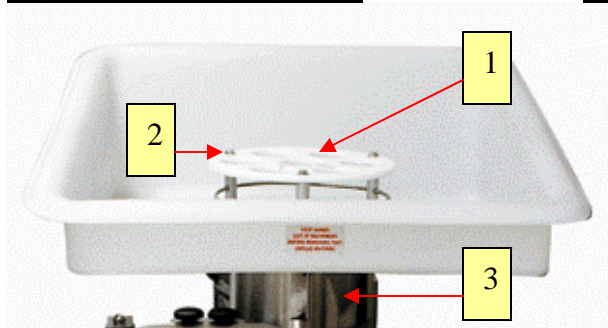
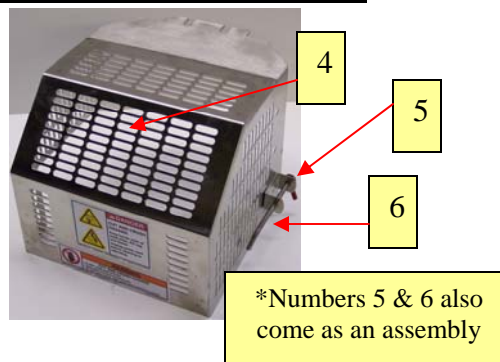
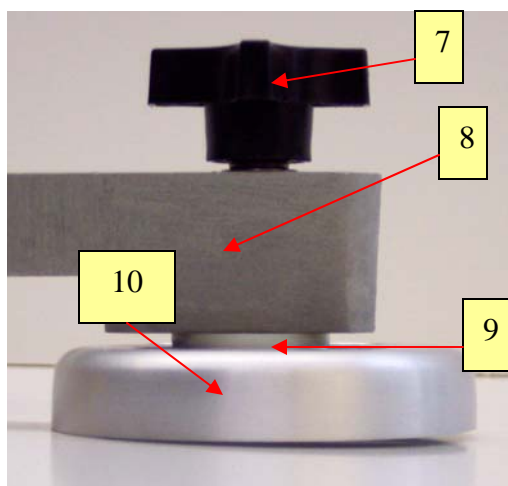
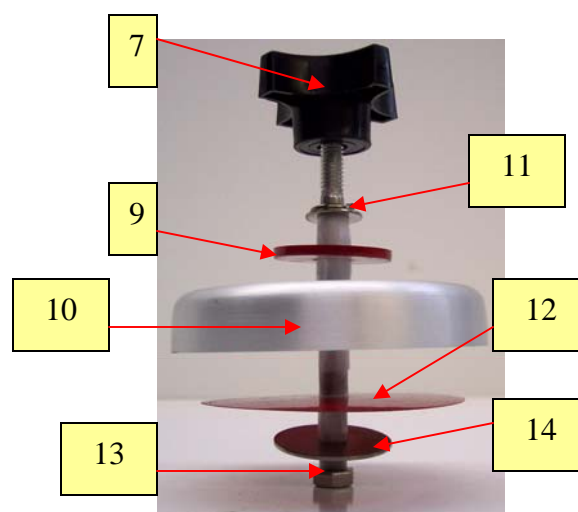
Poly Coved Feed TrayMold Plate Guard AssemblyKnock Out Cup AssemblyKnock Out Cup Exploded View

*Knock Out Cup Hardware is also sold as an assembly.
 -Knock Out Cup Assembly w/ Hardware is Part #571
 -Knock Out Cup Hardware **Only** is Part #571-H1

<u>Item#</u>	<u>Description</u>	<u>Part #</u>
1	Feed Tray Guard Assembly	543
2	Feed Tray Guard Hardware	541-B
3	Stainless Support	554
4	Mold Plate Guard Assembly	550SC
5	Push Rod Collar	553-1B
6	Push Rod	553-5
5&6	Push Rod and Collar Assembly	553
7	Knock Out Knob	571-7
8	Knock Out Arm (partial view)	502B
9	Knock Out Cup Plastic Washer	571-6
10	Round Knock Out Cup	571-1
11	Knock Out Cup Flat Washer and Lock Washer	571-8
12	Knock Out Air Valve (shown in red for visual affect)	571-4
13	Knock Out Cup Bolt	571-9
14	Knock Out Cup Fender Washer	571-10

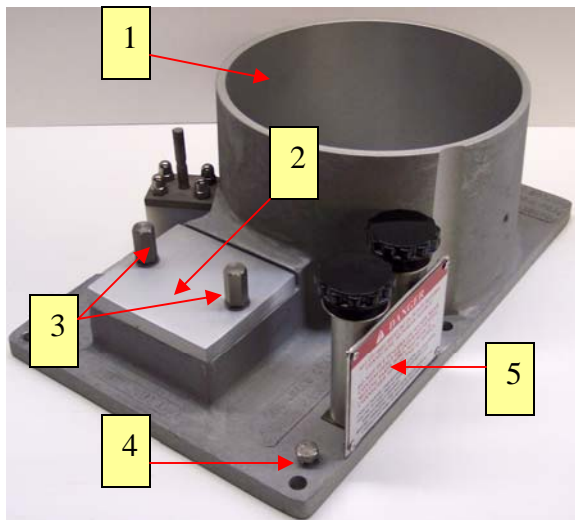
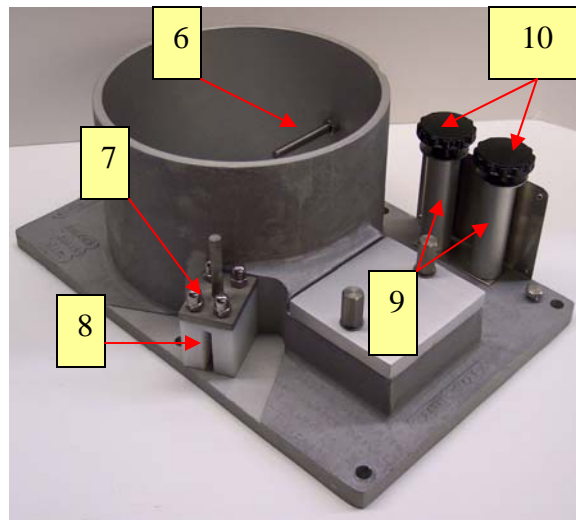
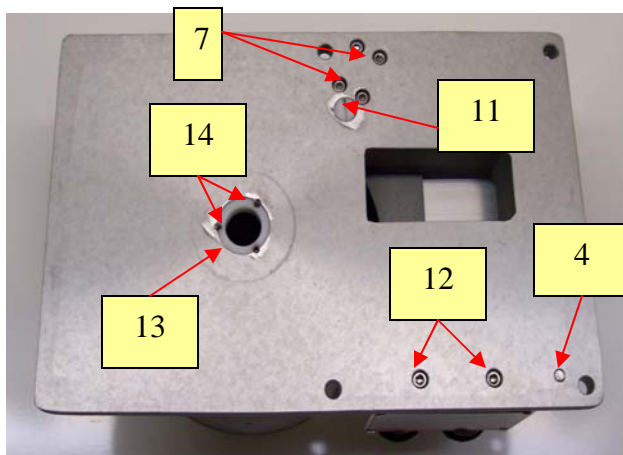
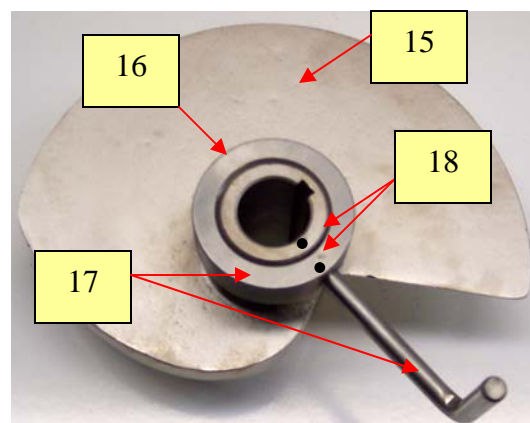
Hopper Front View**Hopper Rear View****Hopper Bottom View****Feeder Top View**

<u>Item#</u>	<u>Description</u>	<u>Part #</u>
1	Hopper Casting	545
2	Chamber Lid	545-A
3	Hex Hold Down Bolt (also used as Hopper hold down)	556B
4	X-Bolt	570
5	Guard Post Guard	551-B
6	Meat Stop	555
7	Pressure Plate Block Hardware	548-C
8	Pressure Plate Block	547
9	Mold Plate Guard Post	551
10	Mold Plate Guard Knob and Washer	550-1
11	Hopper Threaded Plug	607
12	Guard Post Screw	551-A
13	Hopper Nylon Bushing	603
14	Hopper Nylon Bushing Set Screw	604
15	Feeder	557
16	Mixer Collar Set Screw	559
17	Mixer Collar	558
18	Witness Marks (one on Feeder and one on Mixer Collar)	N/A

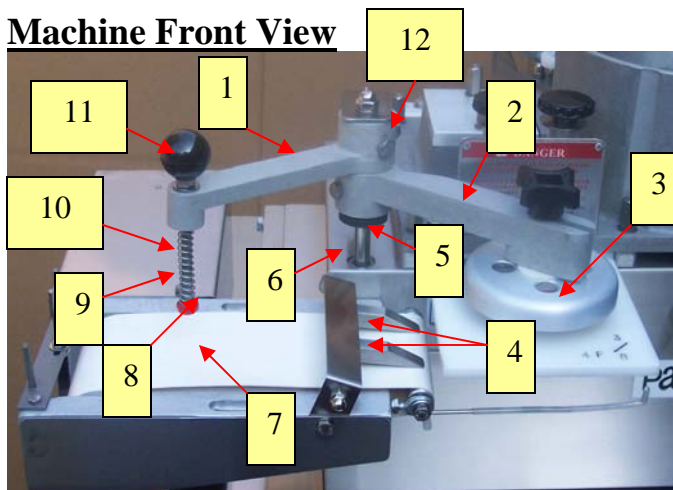
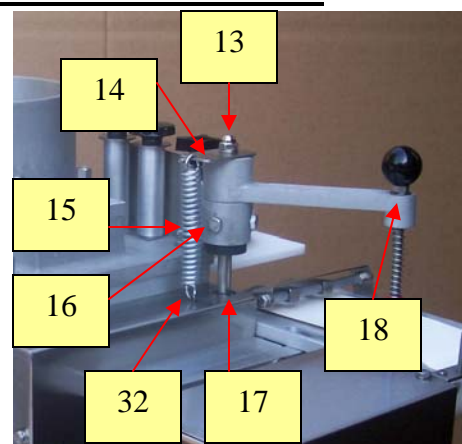
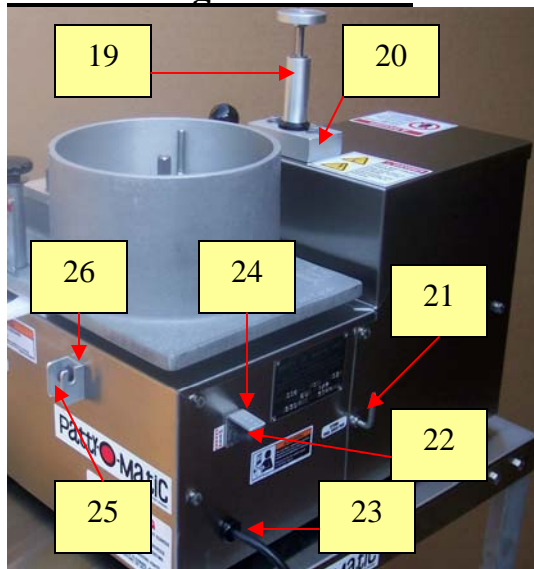
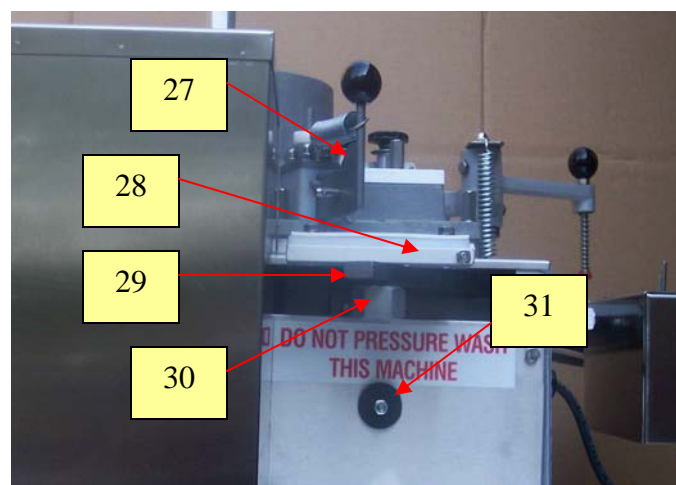
Machine Front View**Machine Left Side View****Machine Right Side View****Machine Rear View**

<u>Item #</u>	<u>Description</u>	<u>Part #</u>
1	Paper Interleaver Arm and Bolts	505
2	Knock Out Arm and Bolts	502B
3	Knock Out Cup	571-1
4	Paper Weight	532
5	Large Knock Out Bumper	504
6	Knock Out Shaft	449
7	Conveyor Belt	534
8	Pressure Bolt Tip	506D
9	Pressure Bolt	506
10	Pressure Foot Spring	508
11	Pressure Foot Ball Knob	506B
12	Paper Interleaver Arm Bolt	505-1
13	Knock Out Shaft Acorn Nut	503
14	Knock Out Spring Tab	498C
15	Knock Out Spring	490
16	Knock Out Arm Bolt	502-1
17	Knock Out Shaft Bushing (white poly bushing that is pressed into Machine Frame)	462
18	Paper Interleaver Arm Bushing (white poly bushing pressed into the Paper Interleaver Arm)	505-1B

<u>Item#</u>	<u>Description</u>	<u>Part#</u>
19	Feed Tray Tower	620-5
20	Feed Tray Tower Block	620-6
21	Tool Holder	601
22	On/Off Switch	500
23	Power Cord	115-01
24	On/Off Switch Guard	501
25	Key Latch	609-A1
26	Plunger Switch	608-1B
27	Ring Pin Pressure Plate	546-3
28	Mold Plate Back Drive	564
29	Connecting Arm	455
30	T-Knob	567
31	Grease Fitting	PS701
32	Knock Out Spring Cotter Pin	490D

Many parts are also sold as assemblies. Please contact the factory for further information:
 Toll Free in the U.S.A. 877-938-5244
 Outside the U.S.A. 732-938-2757

Paper Interleaver Top View (Conveyor Belt is Removed for Visual)

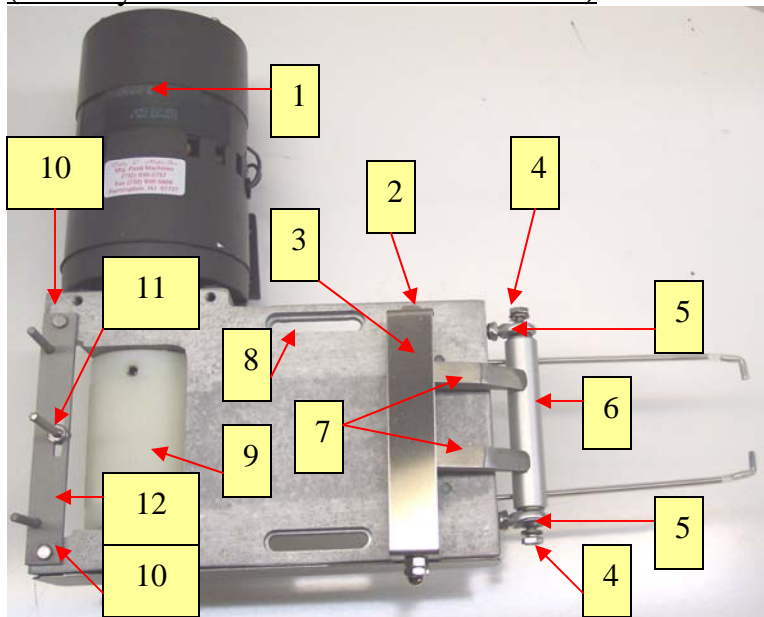

Paper Motor

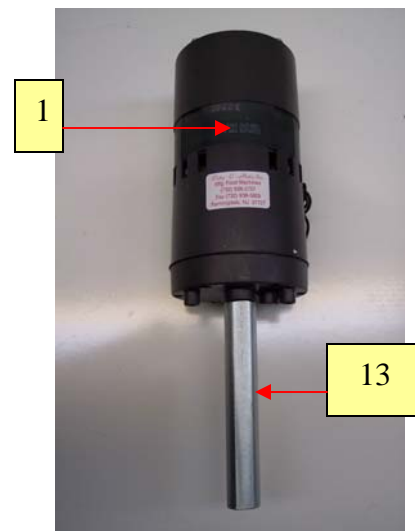

Paper Return Bracket

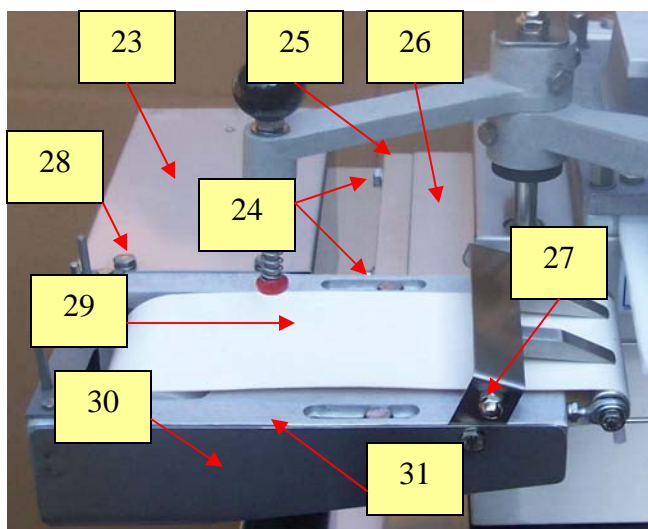
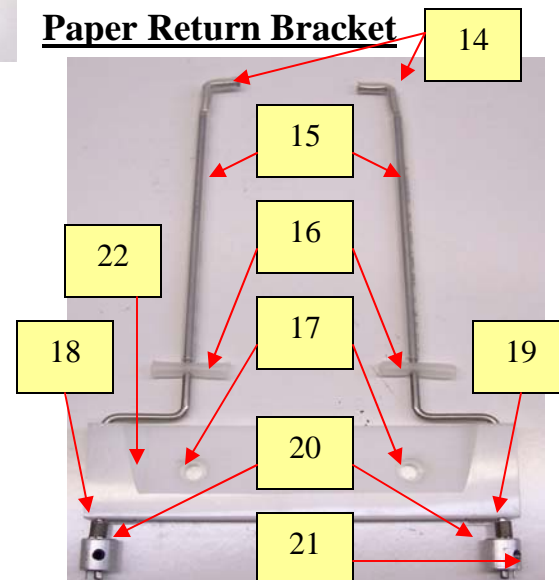

<u>Item #</u>	<u>Description</u>	<u>Part #</u>
1	Paper Interleaver Motor c/w Extension Shaft	516
2	Weight Shaft	527
3	Weight Shaft Support	529
4	Rod End Hardware	523
5	Rod End Bearing (2 required)	522
6	Paper Interleaver Front Pulley	521
7	Paper Weight (2 required)	532
8	Interleaver Adjustment Slots	N/A
9	Paper Interleaver Back Pulley	520
10	Pin Holder Bolt and Nuts (2 required)	526
11	Paper Pin, Nuts, and Washers	525
12	Paper Pin Assembly	524-A
13	Motor Extension Shaft and Screws	517
14	Paper Sleeve Stop	248A
15	Stainless Steel Paper Pivot Rod	247

<u>Item#</u>	<u>Description</u>	<u>Part#</u>
16	Paper Stop	248
17	2 Return Bracket Mounting Screws	249
18	Left Return Spring	246L
19	Right Return Spring	246R
20	Spring Adjusting Collar (2 required)	244
21	Set Screw (one in each collar)	245
22	Pivot Rod Support Bracket	243
23	Interleaver Motor Cover	537
24	Interleaver Support Hardware	499
25	Paper Attachment Support Bar	497
26	Interleaver Support Bar Spacer	498
27	Weight Shaft Hardware	528
28	Motor Cover bolts	538
29	Conveyor Belt	534
30	Conveyor Belt Guard	536
31	Paper Interleaver Casting Frame	519

Ring Pin Pressure Plate

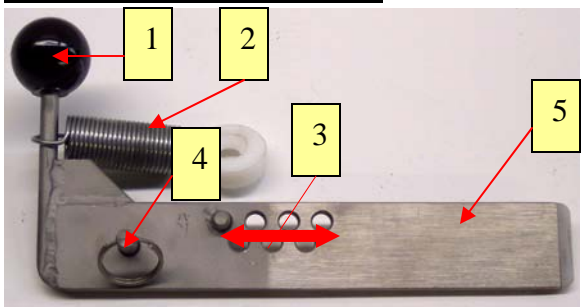

Mold Plate Bottom View

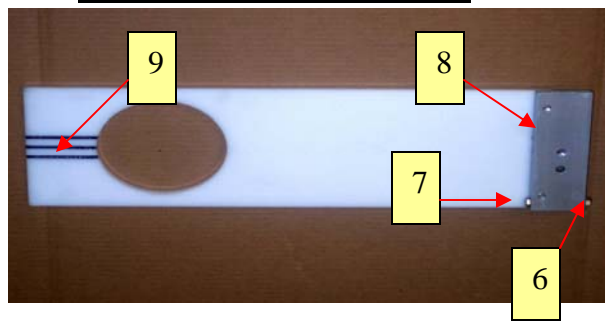

Mold Plate Side View

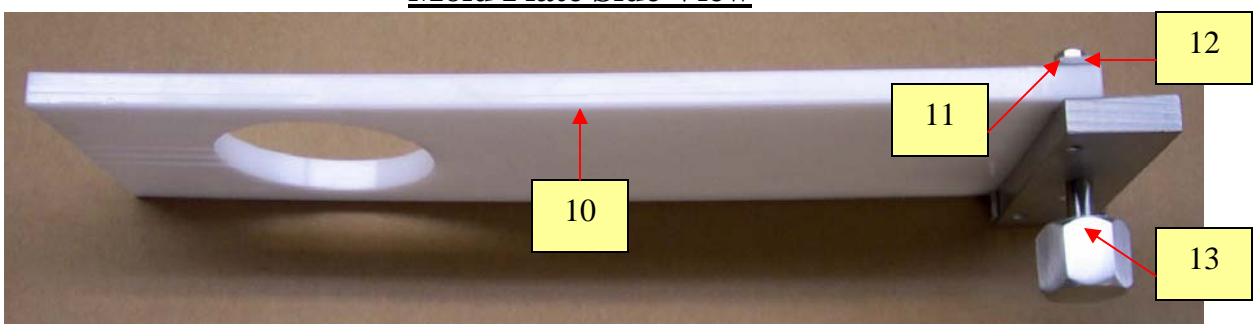

Hopper and Feeder Assembled Top View

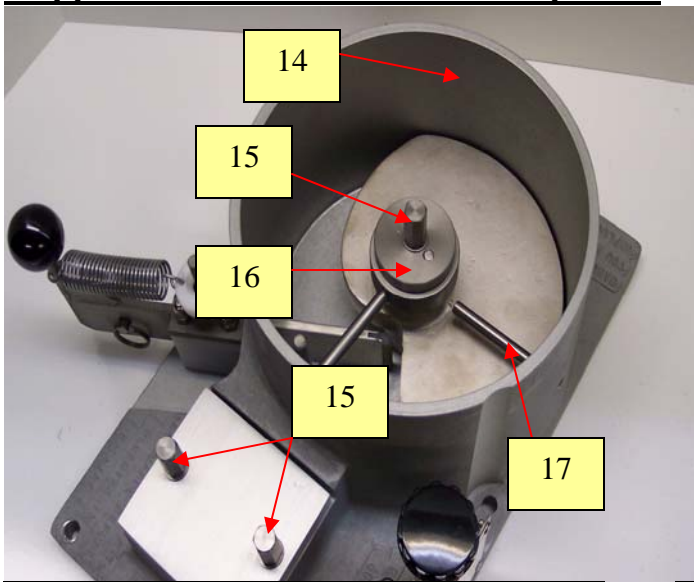

Feeder Washer & Shear Pin

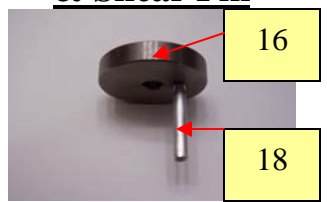

Spacer Plate

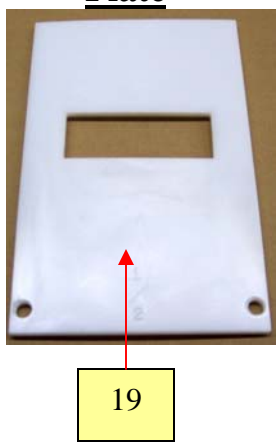

Hold Down Bolt

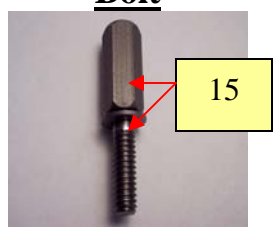

Item #	Description	Part #
1	Pressure Plate Ball Knob	546D
2	Pressure Plate Spring	549
3	Ring Pin Adjustment Holes	N/A
4	Ring Pin (shown in the storage hole)	546C
5	Ring Pin Pressure Plate	546-3
6	Back Drive Stop Bolt Nut	566
7	Back Drive Stop Bolt	565
8	Mold Plate Back Drive	564
9	Air Grooves (colored for visual)	N/A
10	Round Mold Plate	563-1
11	Set of Back Drive Hardware	568A
12	Back Drive Clamp	568

Item #	Description	Part #
13	T-Knob	567
14	Hopper Casting	545
15	Hold Down Bolt	556B
16	Feeder Washer	560
17	Meat Stop	555
18	Shear Pin	562
19	Spacer Plate (Specify Stamp)	569

Part # 563 - Mold Plate Assembly
 -Includes Round Mold Plate,
 Back Drive Assembly and
 Knock Out Cup Assembly

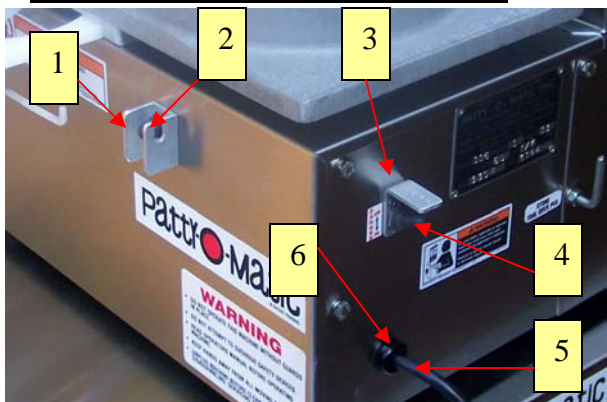
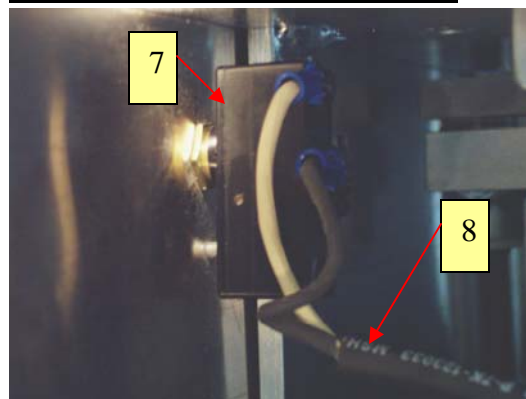
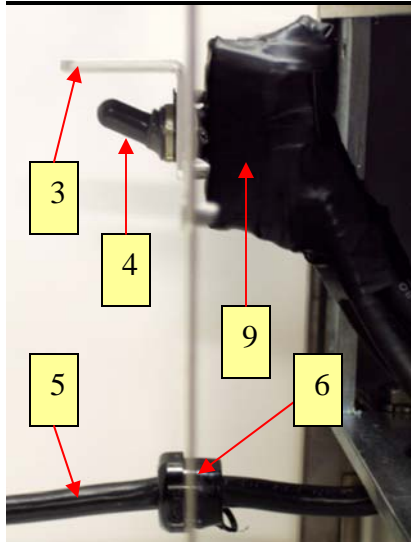
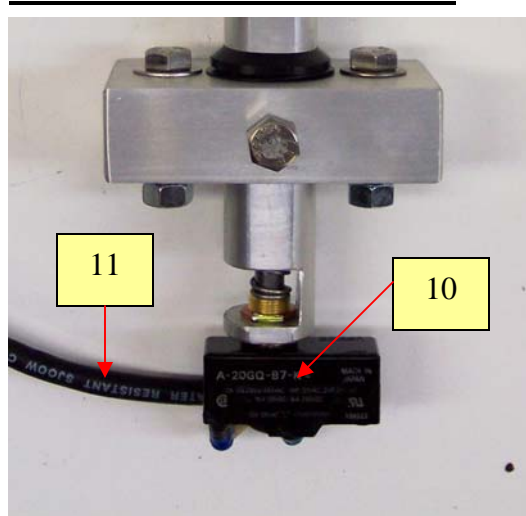
Machine Switches Front View**Guard Switch Interior View****On/Off Switch Interior View****Tower Switch Interior View**

<u>Item#</u>	<u>Description</u>	<u>Part #</u>
1	Key Latch	609-A1
2	Plunger Switch Boot	608-1C
3	On/Off Switch Guard	501
4	On/Off Switch Boot	500B
5	Power Cord	115-01
6	Wire Grommet	487
7	Guard Switch	608-1B
8	Guard Switch Wire	608-1D
9	On/Off Switch (shown insulated in electrical tape)	500
10	Tower Switch	620-10B
11	Tower Switch Wire	620-10A

Part # 608-5A – Includes Guard Switch and Wire
 Part # 620-10B – Includes Tower Switch and Wire

Many other parts are also sold as assemblies. Please contact the factory for further information:
 Toll Free in the U.S.A. 877-938-5244
 Outside the U.S.A. 732-938-2757
 P.O.Box 404 Farmingdale, NJ 07727

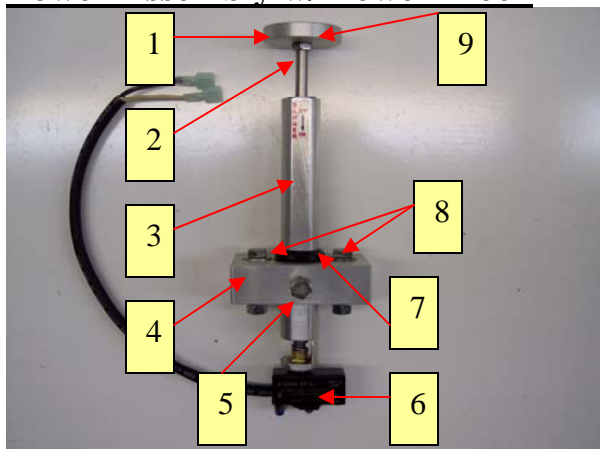
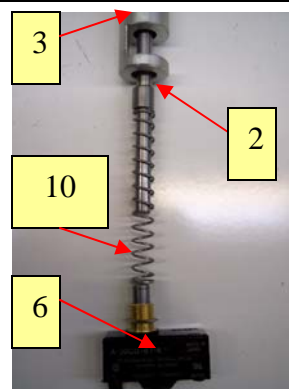
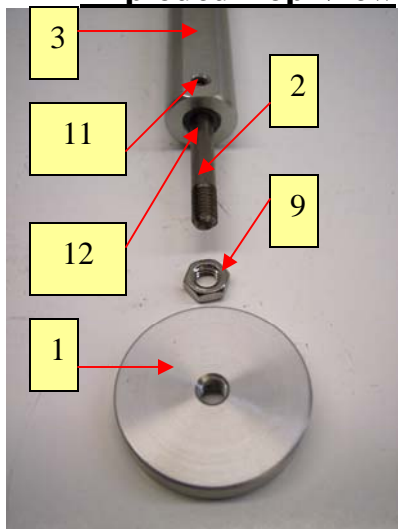
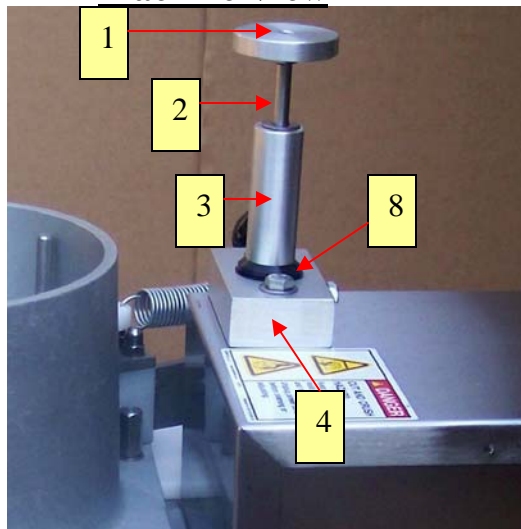
Tower Assembly w/ Tower Block**Tower Assembly
Exploded Bottom View****Tower Assembly
Exploded Top View****Tower Assembly
Machine View**

<u>Item#</u>	<u>Description</u>	<u>Part #</u>
1	Tower Pad	620-08
2	Tower Stem	620-3
3	Tower Rod	620-5
4	Tower Block	620-6
5	Tower Locator Lock Bolt	620-7
6	Tower Switch	620-10B
7	Rubber Seal	464S
8	Tower Block Hardware	620-8
9	Tower Jam Nut	620-06
10	Tower Spring	620-9
11	Tower Set Screw	620-14
12	Tower Bushing	620-4

Many parts are also sold as assemblies. Please contact the factory for further information:
 Toll Free in the U.S.A. 877-938-5244
 Outside the U.S.A. 732-938-2757

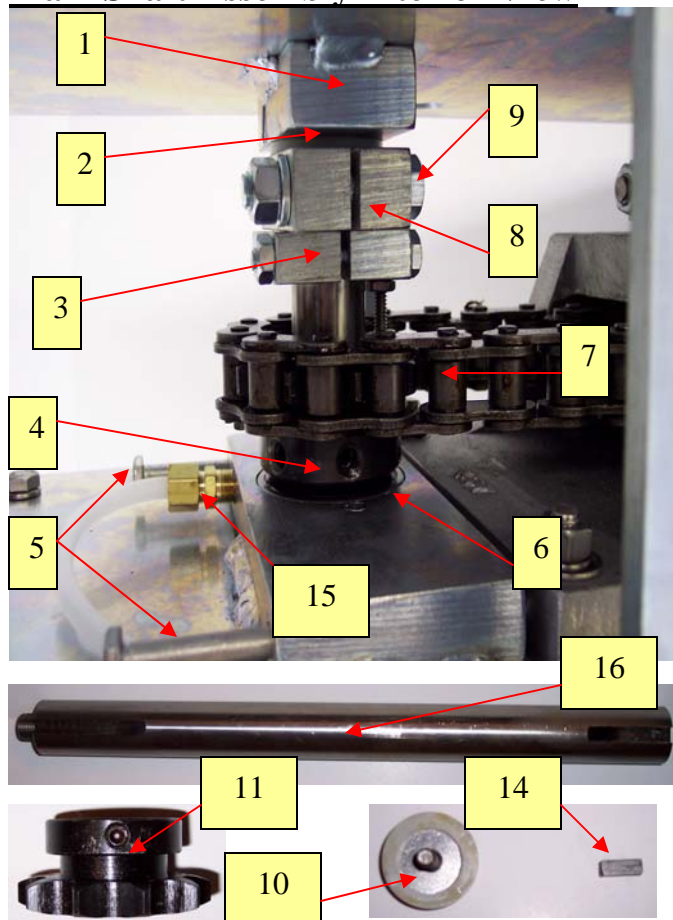
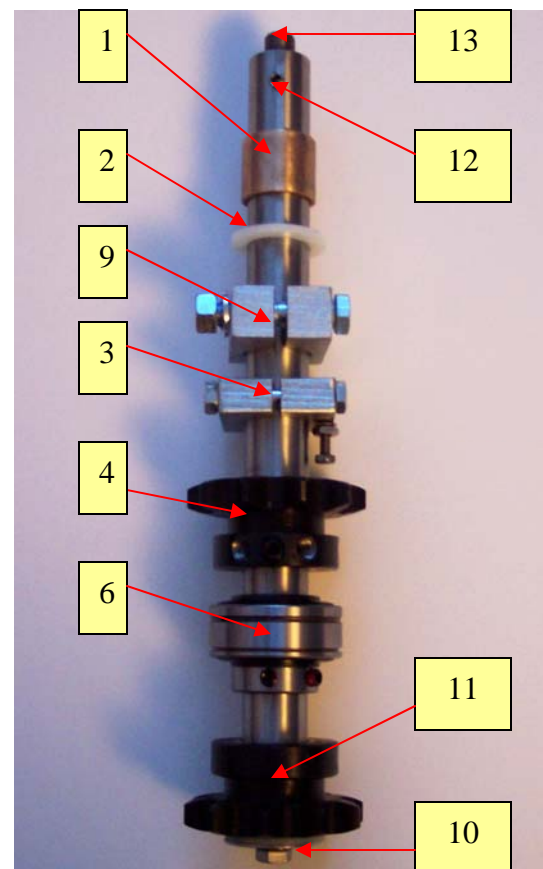
Main Shaft Assembly Interior View**Main Shaft
Exploded View**

<u>Item#</u>	<u>Description</u>	<u>Part #</u>
1	Main Shaft Bushing (pressed into Machine Frame)	470
2	Main Shaft Thrust Washer	469-1
3	Secondary Shaft Clamp	467A
4	Timing Sprocket	465T
5	Chain Slack Adjuster Bolts	463
6	Main Shaft Bearing (pressed into Machine Frame)	464A
7	Timing Chain and Link	471
8	Main Shaft Clamp	467
9	Main Shaft Clamp Hardware	468
10	Main Shaft Fender Washer and Hardware	240-1
11	Main Shaft Driven Sprocket	240
12	Main Shaft Threaded Insert Set Screw	464-2
13	Main Shaft Insert	464-1
14	Main Shaft Sprocket Key	241
15	330A Grease Line System	704
16	Main Shaft C/W Insert and Set Screw	464

Crank Housing Assembly Side View

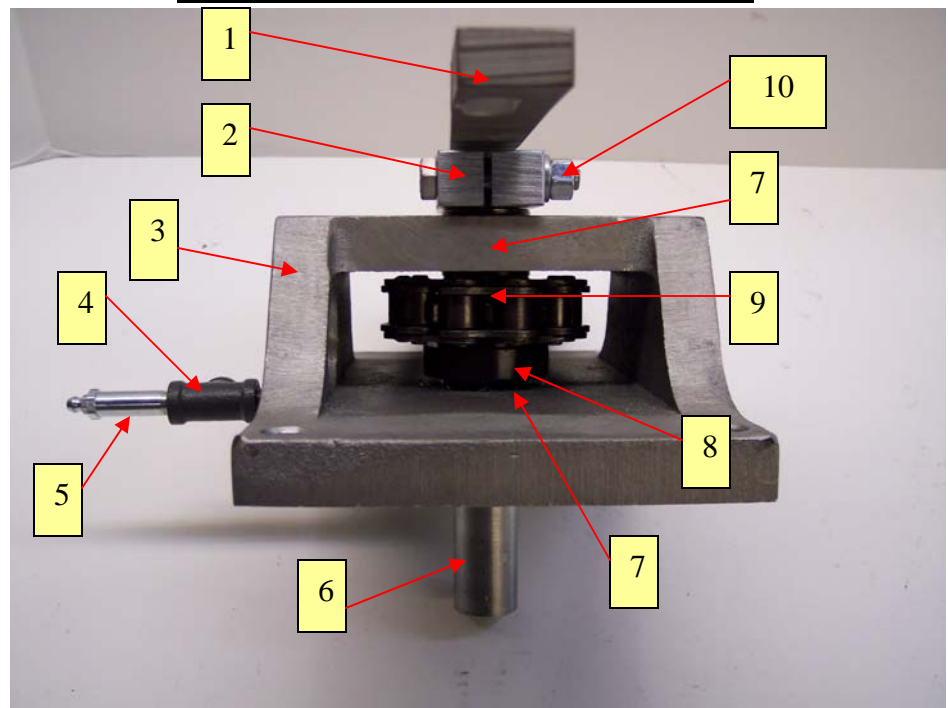

**Crank Shaft Assembly
Exploded View**

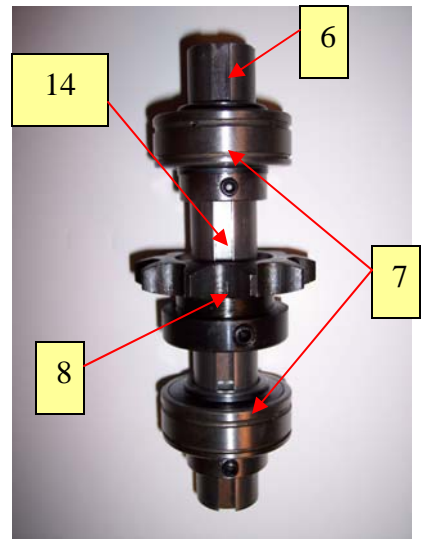

Crank/Connecting Arm Assembly

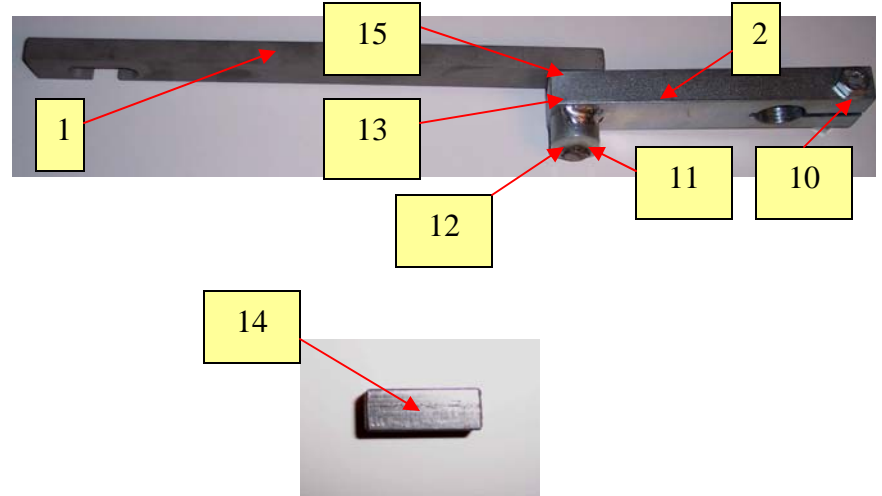

<u>Item #</u>	<u>Description</u>	<u>Part #</u>
1	Connecting Arm	455
2	Crank Arm	452
3	Crank Shaft Housing Casting	457
4	Grease Line T	703
5	Outside Grease Fitting	701
6	Crank Shaft	456
7	Crank Housing Bearing (pressed into Crank Housing)	457A

<u>Item #</u>	<u>Description</u>	<u>Part #</u>
8	Crank Shaft Sprocket	460
9	Timing Chain and Link	471
10	Crank Arm Hardware	453
11	Connecting Arm Thrust Washer	456B
12	Connecting Arm Cotter Pin	455A
13	Connecting Arm Bushing (white poly bushing pressed into the Connecting Arm)	455-1
14	Sprocket Key	461
15	Connecting Arm Spring Washer (Between the Connecting and Crank Arm)	455C

**Part # 459 – Crank Housing Hardware
-Holds Crank Housing to Machine**

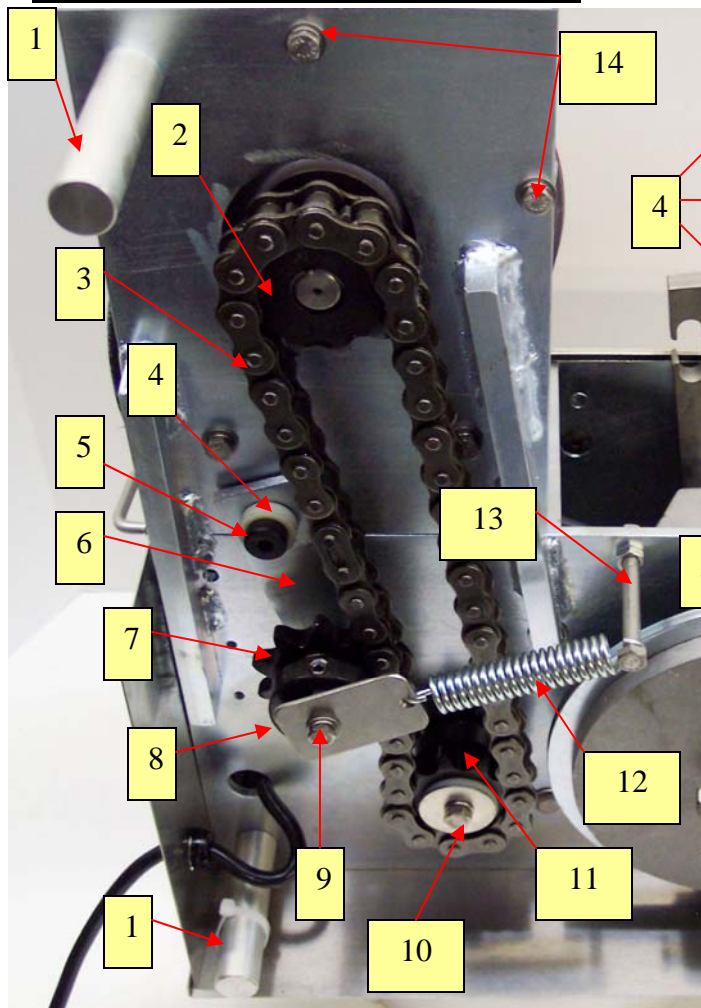
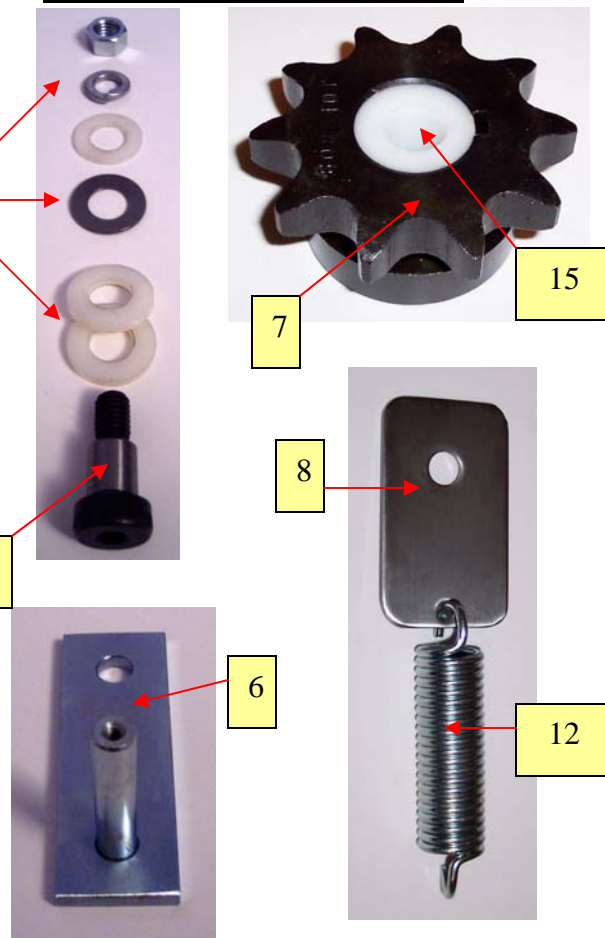
Motor to Main Shaft Bottom View**Idler Arm Assembly Parts**

**Part # 229 – Idler Arm Assembly
-Includes spring, tab, arm, and all
hardware**

<u>Item#</u>	<u>Description</u>	<u>Part #</u>
1	Machine Legs (set of 4)	446
2	Motor Drive Sprocket	236
3	Motor to Main Shaft Chain and Link	239
4	Idler Arm Shoulder Bolt Hardware	229B
5	Idler Arm Shoulder Bolt	229A
6	Idler Arm	230-A
7	Idler Arm Sprocket and Bushing Assembly	232
8	Idler Arm Spring tab	231A
9	Idler Arm Spring Tab Hardware	231B
10	Main Shaft Fender Washer and Hardware	240-1
11	Main Shaft Driven Sprocket	240
12	Idler Arm Spring	231
13	Idler Arm Spring Bolt and Hardware	235
14	Gear Head Motor Mounting Hardware(set of5)	284B
15	Idler Arm Sprocket Bushing	234

Knock Out Cam Bottom View

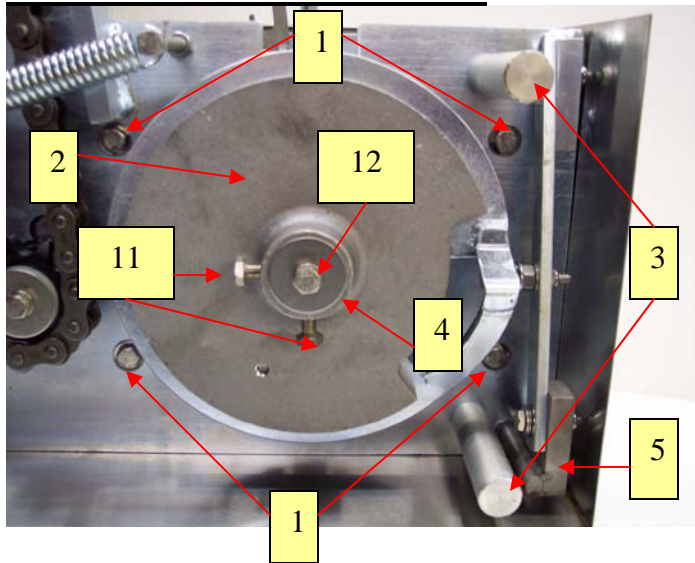

Knock Out Lever Assembly

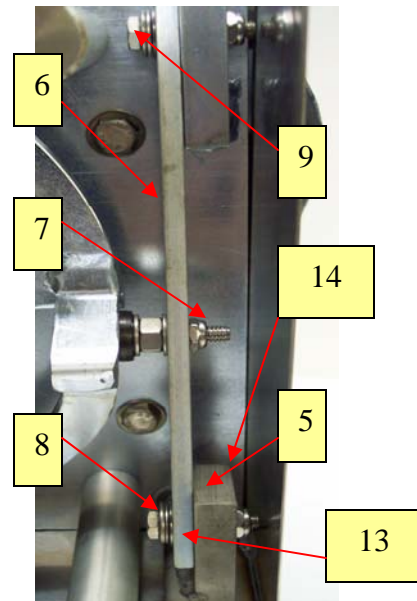

Knock Out Shaft and Lever Assembly

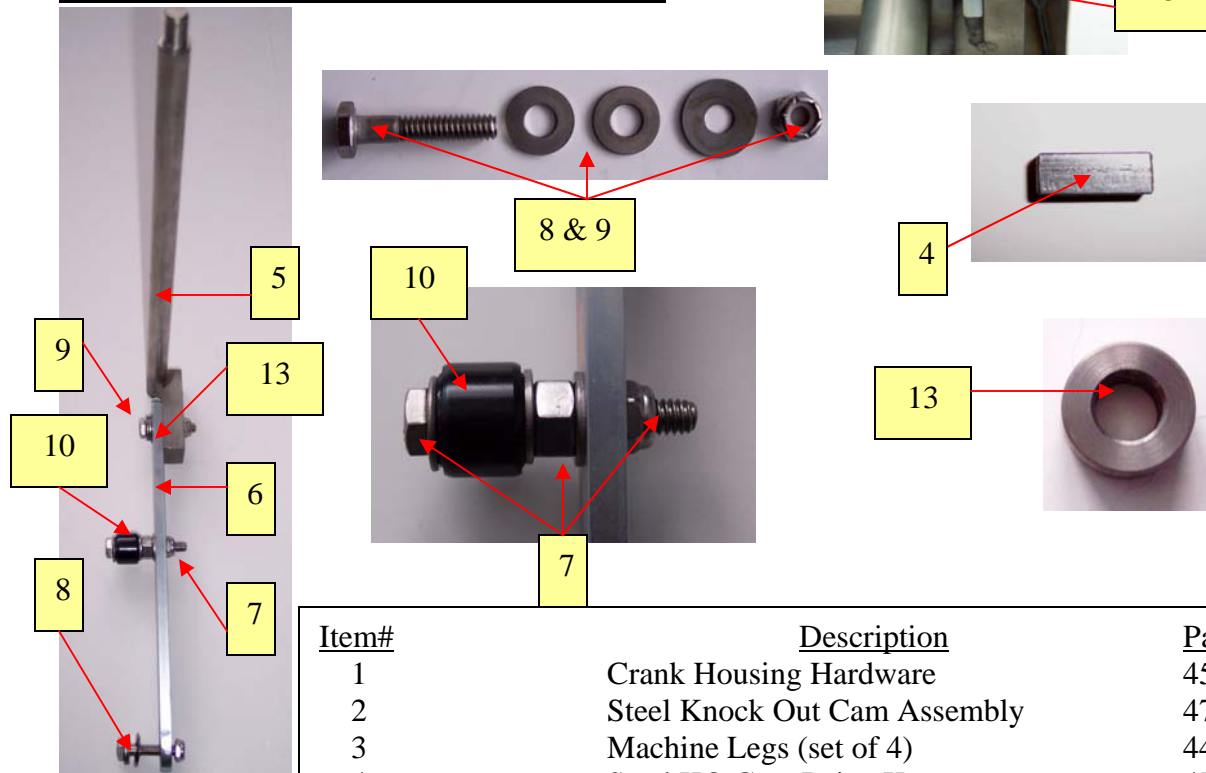

Part # 450X
Knock Out
Lever Assembly
 -Includes Lever,
 Bushing, Cam
 Bearing, and all
 Hardware

<u>Item#</u>	<u>Description</u>	<u>Part #</u>
1	Crank Housing Hardware	459
2	Steel Knock Out Cam Assembly	472-S
3	Machine Legs (set of 4)	446
4	Steel KO Cam Drive Key	477-1
5	Knock Out Shaft	449
6	Knock Out Lever	450
7	Cam Follower Bearing Hardware	475
8	Knock Out Lever Hardware	451
9	Knock Out Lever Bushing Hardware	450B
10	Cam Follower Bearing	474
11	Steel Knock Out Cam Bolts	472-S1
12	Steel KO Cam Keeper Bolt and Hardware	472-S2
13	Knock Out Lever Bushing(sits inside Knock Out Lever)	450A
14	Knock Out Shaft Bushing(white poly bushing pressed into Machine Frame)	462

Main Motor Side View

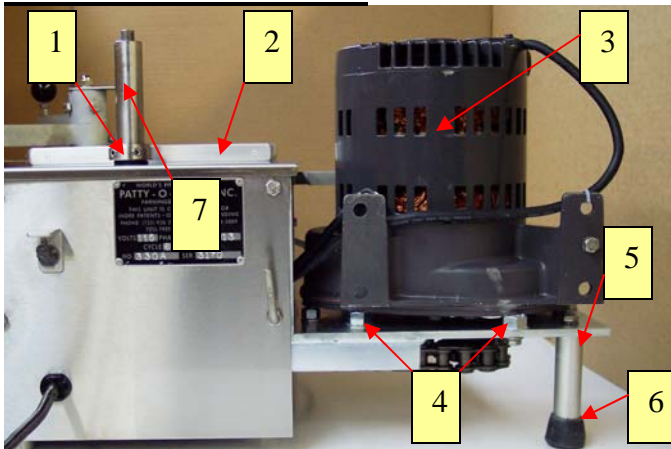

Main Shaft Machine View

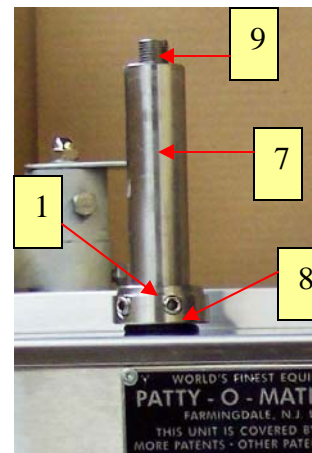

Mold Plate Guide Rails Front View

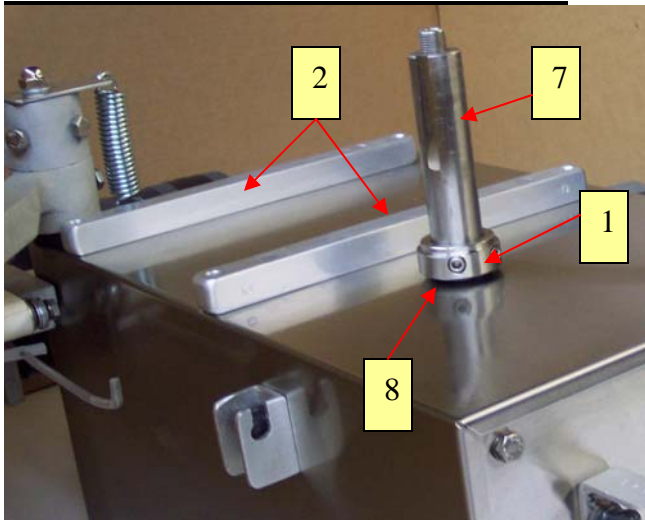

Mold Plate Guide Rail

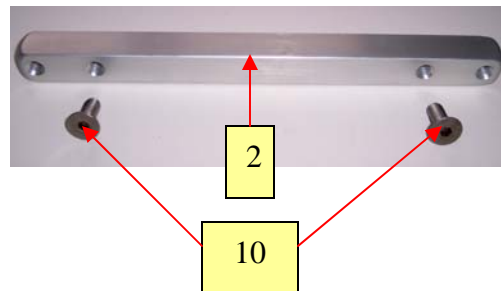

Please call factory for instructions on installing new Mold Plate Guide Rails
 Toll Free in the U.S.A. 877-938-5244
 Outside the U.S.A. 732-938-2757

<u>Item#</u>	<u>Description</u>	<u>Part #</u>
1	Hopper Bushing Set Collar	603D
2	Mold Plate Guide Rail	494
3	Gear Head Motor	284
4	Motor Spacer	284A
5	Machine Legs (set of 4)	446
6	Rubber Feet (set of 4)	448
7	Main Shaft C/W Insert and Set Screw	464
8	Hopper Bushing Set Collar O-Ring	603E
9	Main Shaft Insert	464-1
10	Mold Plate Guide Rail Bolts (set of 2)	495

Paper Interleaver Motor Parts Breakdown

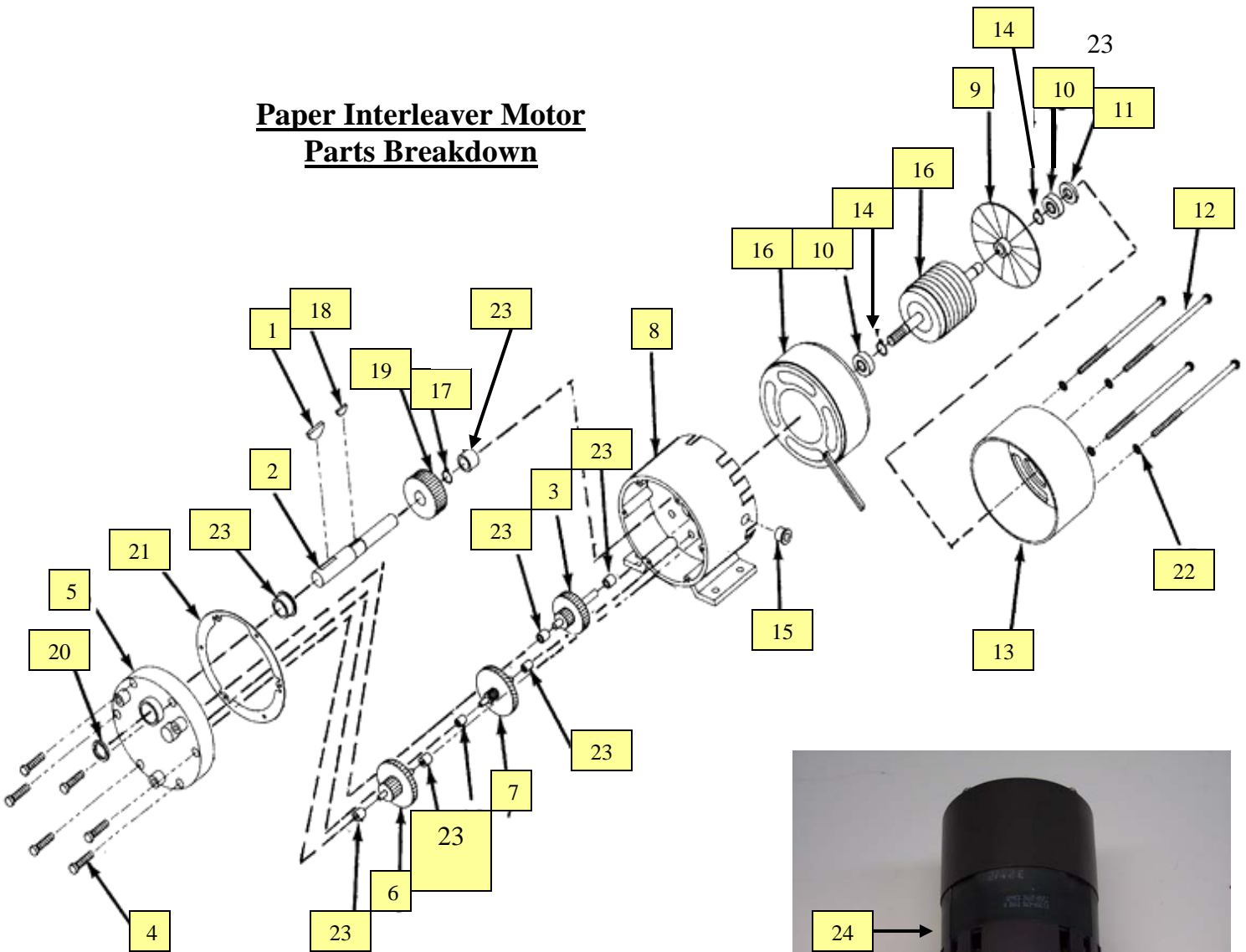

<u>Item #</u>	<u>Description</u>	<u>Part #</u>
1	Key Output Shaft	P00464-0001
2	Output Shaft	J00625-0037
3	Inter Low Sp. Gear	A00559-0001
4	Screw, pan combo	R12022-001
5	Cover Assembly	D006150003
6	Gear, Plastic	A04046-0001
7	High Sp. Gear, Steel	A04046-0002
8	Gear Case Assembly	D00791-0023
9	Fan	E13286-0002
10	Ball Bearing (Contact Factory)	L00647-0002
11	Spring Washer	K02208-0003
12	Screw	R00F10S500Z
13	Endbell	D13066-001
14	Retaining Ring	R02074-0001
15	Snap Bushing	P01206-0003
16	Motor Assembly	V00212AKAJ
17	Snap Ring	R00627-0001
18	Key, Woodruff	P00423-0001
19	Output Gear	H00555-0001
20	Grease Seal	P01694-0026
21	Gear Case Gasket	P11141-0001
22	Lockwasher	R00655-0001
23	Bearing Kit	E13418-0001
24	Paper Interleaver Motor c/w Extension Shaft and Set Screws	516
25	Motor Extension Shaft and Screws	517

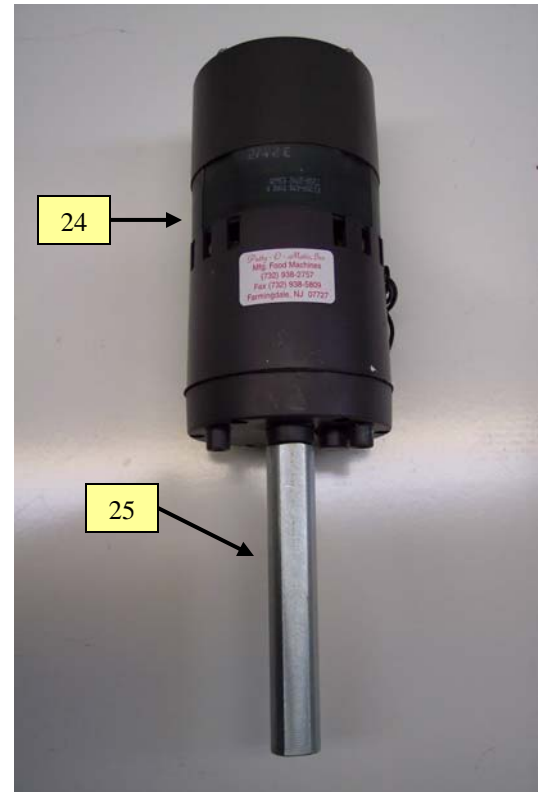

Many parts are also sold as
assemblies. Please contact the factory
for further information:
Toll Free in the U.S.A. 877-938-5244
Outside the U.S.A. 732-938-2757

Main Motor Breakdown

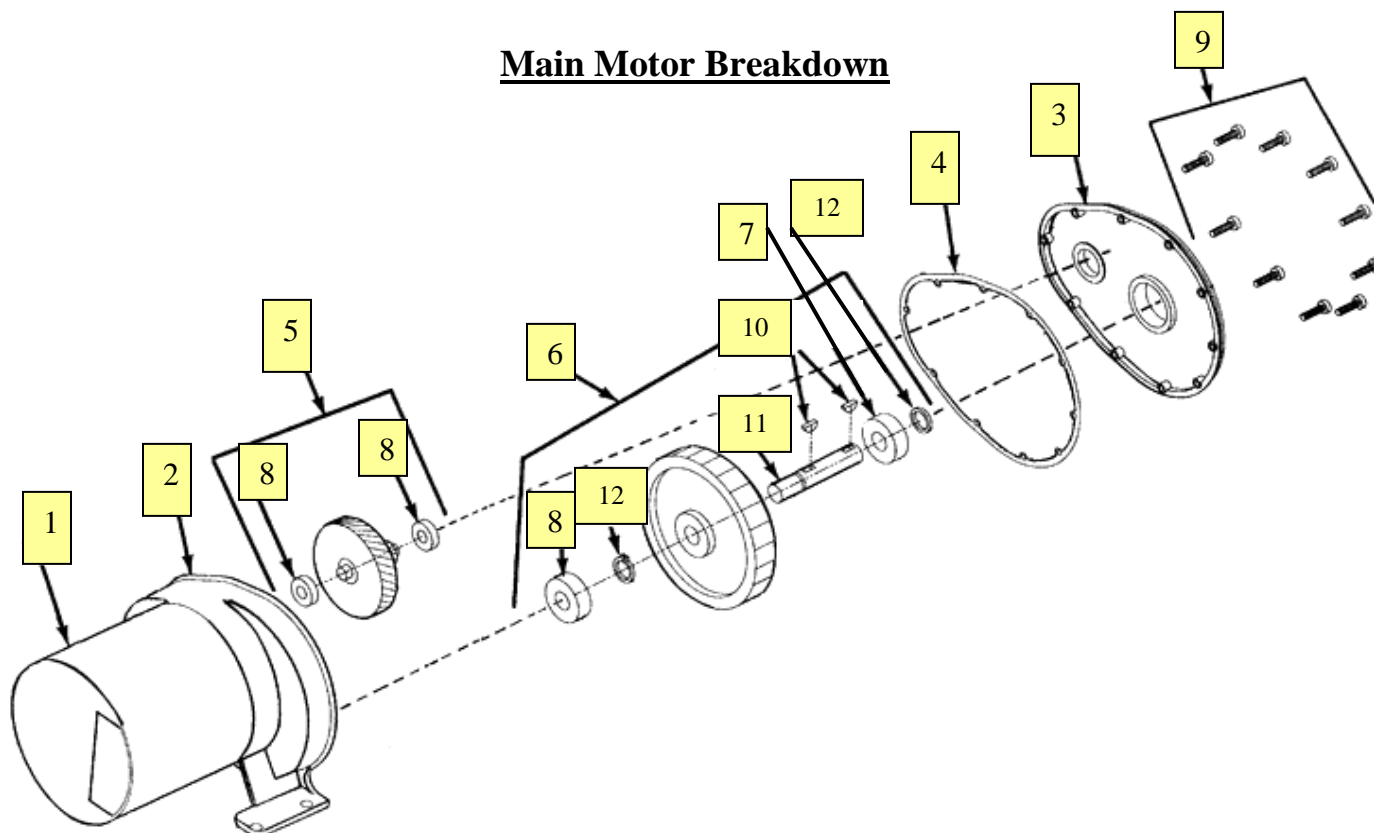

<u>Item#</u>	<u>Description</u>	<u>Part #</u>
1	Motor Assembly	D13807-0001
2	Assembly Case	D12526-0004
3	Cover Assembly	D12525-0001
4	Gasket	P01475-0002
5	High Sp. Gear, Fiber w/ Bearing	A03402-0001
6	Output Gear Assembly	A03403-0001
7	Bearing (Output)	L01792-0001
8	Bearing Kit	D12522-0005
9	Torque Bolt	R12023-0011
10	Key Output Shaft Seal (Woodruff Key #481)	P00464-0001
11	Shaft	J01477-0001
12	Snap Ring	R01477-0001

Many parts are also sold as assemblies. Please contact the factory for further information:
Toll Free in the U.S.A. 877-938-5244
Outside the U.S.A. 732-938-2757
P.O. Box 404 Farmingdale, NJ 07727

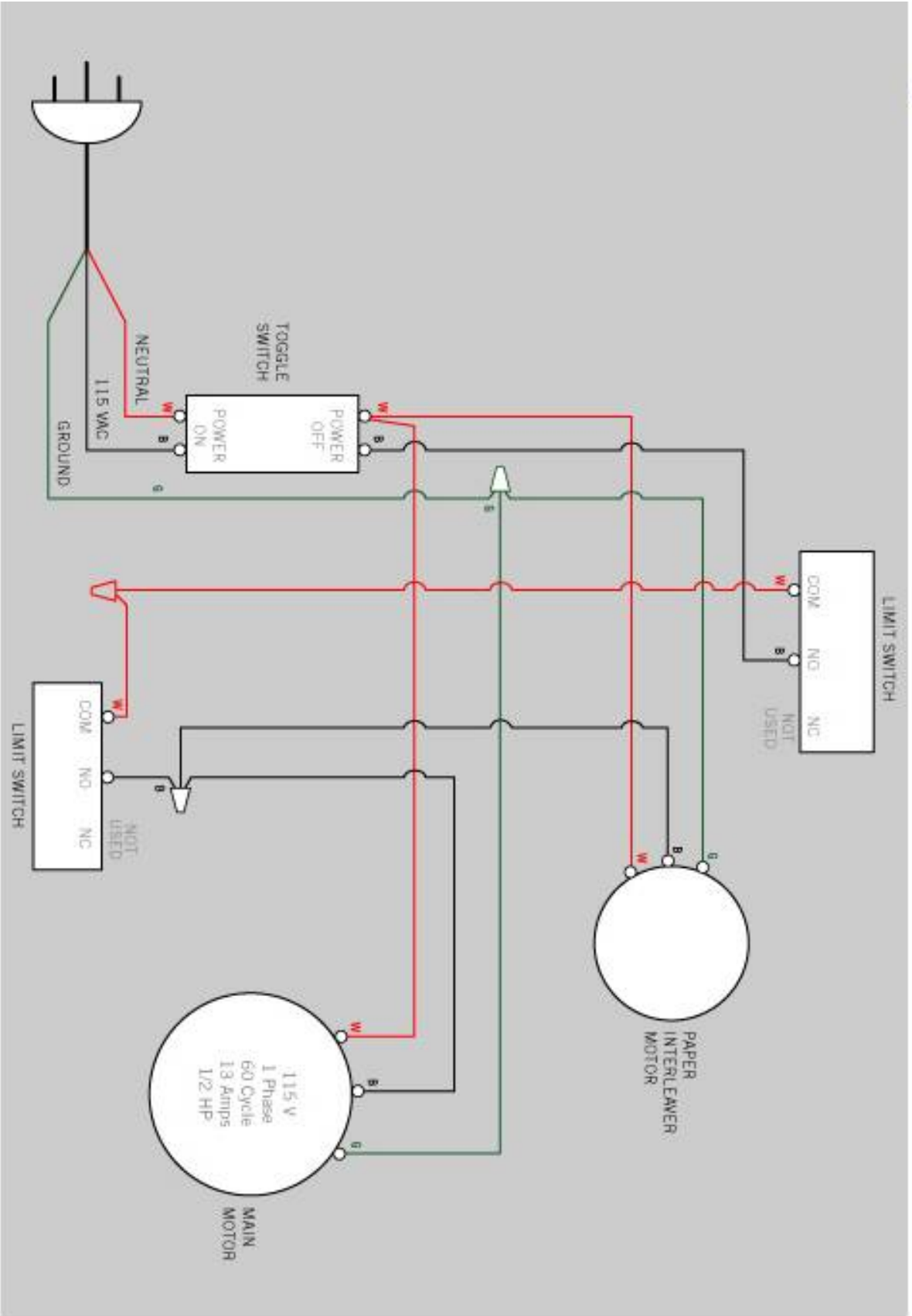

KEY: W = White/Neutral B = Black/115 VAC G = Green/Ground

Model 330A
Warranty Information

This appliance is guaranteed to original purchaser to be free from defects in materials and workmanship.

Warranty shall be limited to repairing or exchanging any part that in our judgment shows evidence of defect within one year of original date of purchase.

In the event of return due to defect in material or workmanship, within the warranty period, please return in original packing case or equivalent.

Our expert factory repair service is provided, and recommended for all repairs, within and beyond the warranty period.

Warranty shall not apply if appliance has been plugged into any current other than that specified; or has been tampered with or altered in any way.

Warranty does not cover parts that wear out from use or parts that are damaged or broken in use; or service claims arising due to failure to follow operating instructions.

This warranty is in lieu of all other warranties, expressed or implied. No representative or other person is authorized or permitted to make any guarantee or to assume for us any liability not strictly in accordance with the foregoing.

If you should have any further questions or require assistance with anything, please do not hesitate to call the factory. We recommend that you are near the appliance at the time of your call. Know the age, serial number of the appliance, and mold plate size. Also it is good to know if all the parts are original or replacement parts. Our Toll Free Number is **877-938-5244**.

Patty-O-Matic, Inc.[®]
THE WORLD'S FINEST FOOD MACHINES

Important Information on Your Machine

Patty-O-Matic Inc. Model 330A

Serial Number _____

Date Purchased _____

Purchased From What Dealer _____

Dealer Address and Phone Number _____

Maintenance Performed on Machine _____

Owner's Notes _____

