

203

INCLUDING: OPERATION, INSTRUCTION, INSTALLATION, MAINTENANCE AND PARTSBOOK

**IMPORTANT: READ THIS MANUAL CAREFULLY BEFORE INSTALLING, OPERATING OR
SERVICING THIS TOOL.**

BEEF SPLITTING SAW

TOOL DATA

MODEL: KENTMASTER 203
ASSEMBLY NO. 1200000
TYPE: ELECTRICAL OPERATED
NET WEIGHT: 206 LB (94 KG)
MOTOR HORSEPOWER: 3HP / 50Hz, 60Hz

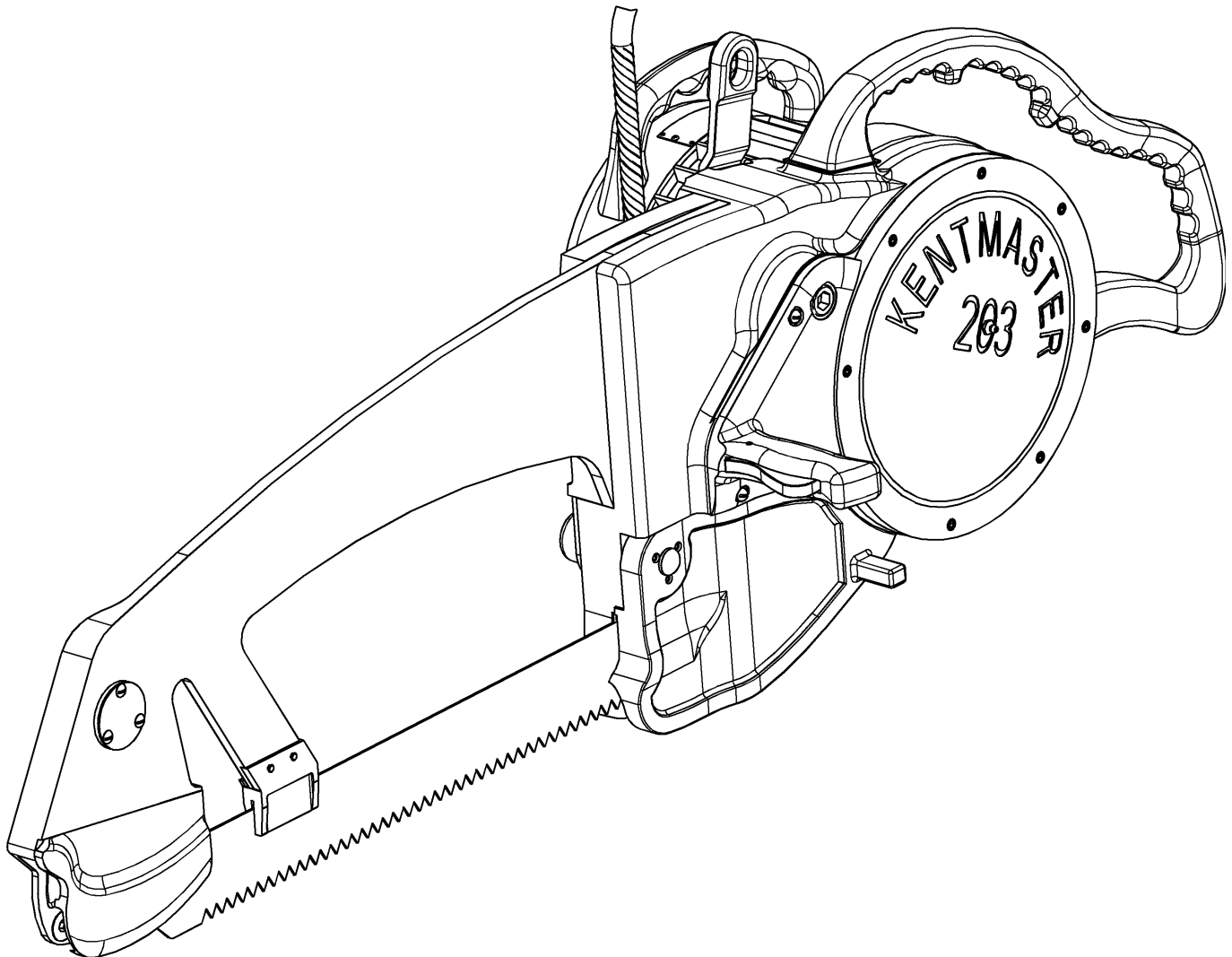

**WARNING**

= Hazards or unsafe practices which could result in severe personal injury, death or substantial property damage.

**CAUTION**

= Hazards or unsafe practices which could result in minor personal injury, product or property damage.

**NOTICE**

= Important installation, operation or maintenance information.

OPERATING AND SAFETY INSTRUCTIONS

**WARNING**

DO NOT OPERATE THIS TOOL UNTIL YOU HAVE READ AND UNDERSTOOD THE SAFETY INSTRUCTIONS AND OPERATING MANUALS.

**WARNING**

DO NOT OPERATE THIS TOOL UNTIL YOU HAVE RECEIVED TRAINING IN THE HANDLING, OPERATION AND USE OF THIS TOOL.

**WARNING**

STOP USING A MALFUNCTIONING OR DEFECTIVE TOOL IMMEDIATELY. REPORT ANY PROBLEMS OR DEFECTS TO YOUR SUPERVISOR FOR REMOVAL OF THE TOOL FROM SERVICE.

**WARNING**

DO NOT ATTEMPT TO REPAIR THE TOOL YOURSELF.

**WARNING**

DO NOT ALLOW UNAUTHORIZED PERSONS TO USE TOOL.

**WARNING**

REMOVE AND DISCONNECT POWER FROM THE TOOL WHEN TOOL IS LEFT UNATTENDED OR IS NOT IN USE.

**WARNING**

NEVER TIE DOWN, BYPASS, ALTER OR MODIFY THE ACTIVATING SWITCHES OR TRIGGERS OF THIS TOOL.

**WARNING**

NEVER MAKE ALTERATIONS OR MODIFICATIONS TO THIS TOOL.

**WARNING**

BE CONSTANTLY AWARE AND ALERT FOR UNSAFE CONDITIONS AND REPORT THEM IMMEDIATELY TO YOUR SUPERVISOR.

**WARNING**

NEVER PLACE YOUR HAND OR ANY PART OF YOUR BODY IN THE CUTTING PATH OF THE TOOL.

**WARNING**

NEVER ALLOW ANYONE ELSE TO PLACE THEIR HANDS OR ANY PART OF THEIR BODY IN THE CUTTING PATH OF THE TOOL.

**WARNING**

DO NOT ACTIVATE CONTROL SWITCHES OR TRIGGERS OF THIS TOOL UNLESS YOU INTEND TO TEST OR OPERATE THIS TOOL.

**WARNING**

DO NOT USE THIS TOOL FOR ANY PURPOSE OTHER THAN IT'S INTENDED PURPOSE.

**CAUTION**

WHEN OPERATING THIS TOOL WEAR THE PROTECTIVE GEAR AND SAFETY EQUIPMENT SUPPLIED TO YOU.

**WARNING**

THE NOISE EMISSION (SOUND PRESSURE LEVEL) AT THE WORKSTATION MAY EXCEED 80 dB (A). EAR AND SOUND PROTECTION GEAR IS REQUIRED.

SERVICE

1. KEEP GOOD RECORDS OF ALL SERVICE ACTIVITY AND INCLUDE TOOL IN PREVENTIVE MAINTENANCE PROGRAM.
2. USE ONLY GENUINE KENTMASTER REPLACEMENT PARTS TO ASSURE PROPER PERFORMANCE OF TOOL.
3. CONTACT THE KENTMASTER SUPPLIER NEAREST YOU FOR PARTS AND CUSTOMER SERVICE INFORMATION.

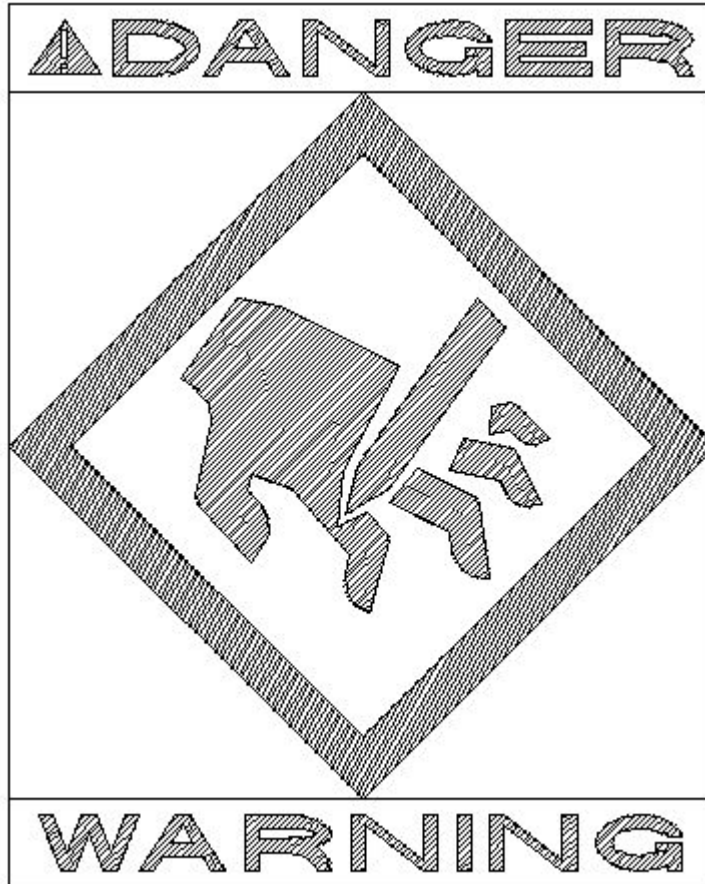

PARTS BOOK

“203” MAIN ASSEMBLY

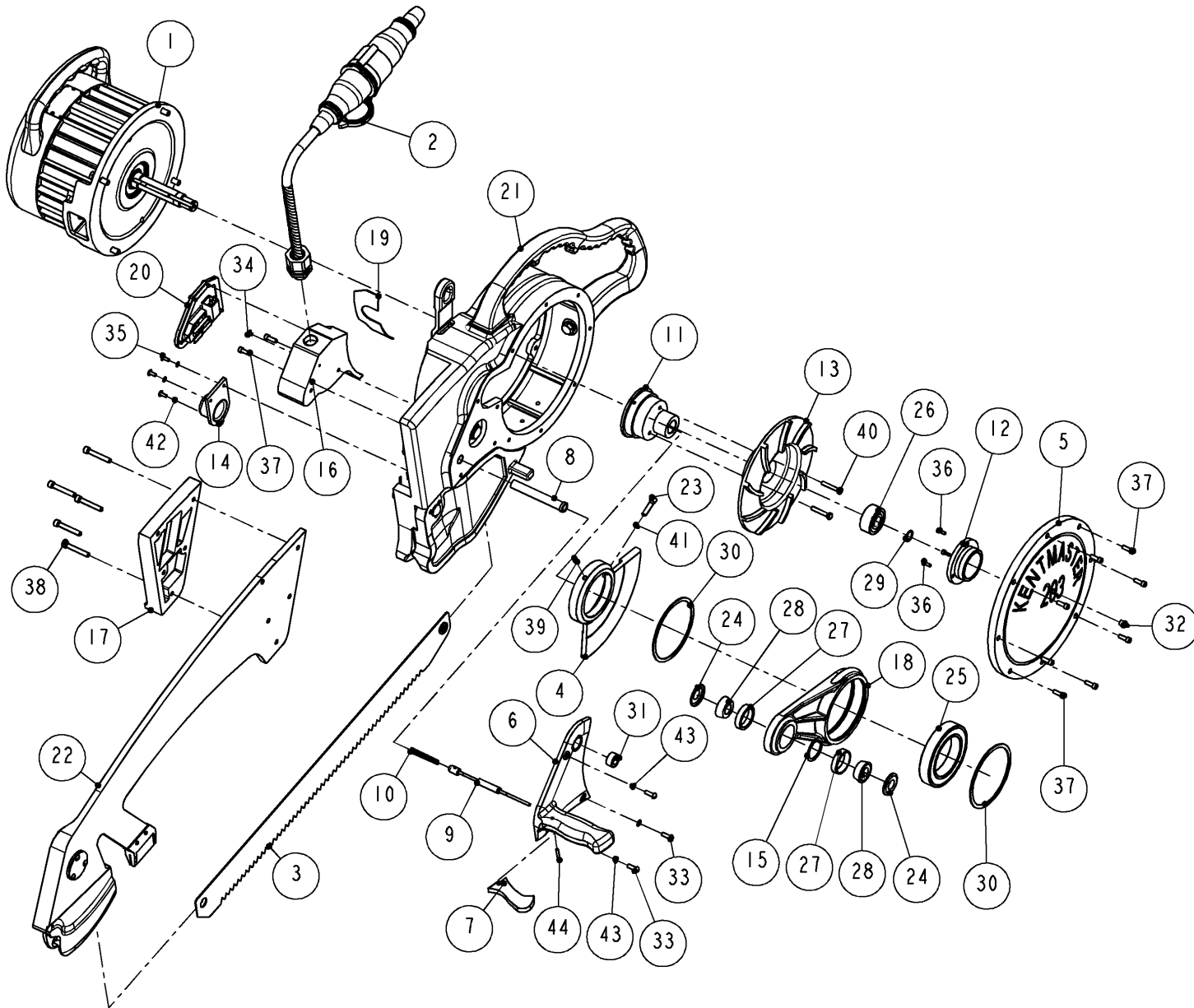

Figure 1 MODEL "203"

KENTMASTER MFG. CO., INC. 1801 SOUTH MOUNTAIN AVE., MONROVIA, CALIFORNIA 91016 UNITED STATES OF AMERICA

☎ TELEPHONE: (626) 359-8888 FAX: (626) 303-5151

1200000: 203 - BEEF SPLITTING SAW			
ITEM	PART #	DESCRIPTION	QTY
1	OPTIONS	MOTOR ASSEMBLY / REQUIRED	1
2	1002420	POWER CORD ASSEMBLY, NON 42V	1
	1002430	POWER CORD ASSEMBLY, 42V	1
3	4100130	BLADE, STANDARD. 3TPI	1
	4100140	BLADE, 4TPI	1
	4100240	BLADE, "SKIP TOOTH". 2TPI	1
4	1200900	BALANCE SEGMENT (60 Hz CYCLE)	1
	1202490	BALANCE SEGMENT (50 Hz CYCLE)	1
5	1200040	COVER, HOUSING	1
6	1200080	HANDLE	1
7	1200180	TRIGGER	1
8	1200190	BUSHING	1
9	1200200	TRIGGER SHAFT	1
10	1200220	SPRING	1
11	1200430	ECCENTRIC	1
12	1200460	BUSHING	1
13	1200670	FLY WHEEL	1
14	1200760	CAP, SPRING COVER	1
15	1201580	SPACER RING	1
16	1201700	WIRE BOX	1
17	1201770	YOKE BLOCK	1
18	1201780	CONNECTING ROD	1
19	1202080	GASKET	1
20	1202540	SWITCH PLATE ASSEMBLY	1
21	1203001	FRAME AND REAR HANDLE ASSEMBLY	1
22	1203002	YOKE AND SUSPENSION ARM	1
23	1702620	SCREW	1
24	3005120	NILOS RING	2
25	3122160	BEARING	1
26	3532040	BEARING	1
27	3650170	TAPER BEARING CUP	2
28	3650420	TAPER BEARIN CONE	2
29	5100780	RETAINING RING	1
30	5604920	RETAINING RING	2
31	7000060	PLUG	1
32	7016100	LUBE FITTING	1
33	8031060	SCREW	3
34	8109020	SCREW	1
35	8110040	SCREW	3
36	8210040	SCREW	3
37	8211060	SCREW	10
38	8213160	SCREW	5
39	8333050	SET SCREW	1
40	8411120	SCREW	2
41	8506650	WASHER	1
42	8507090	WASHER	3
43	8507100	WASHER	3
44	8613180	PIN	1

Figure 2 BOM FOR MODEL "203"

MOTOR ASSEMBLY

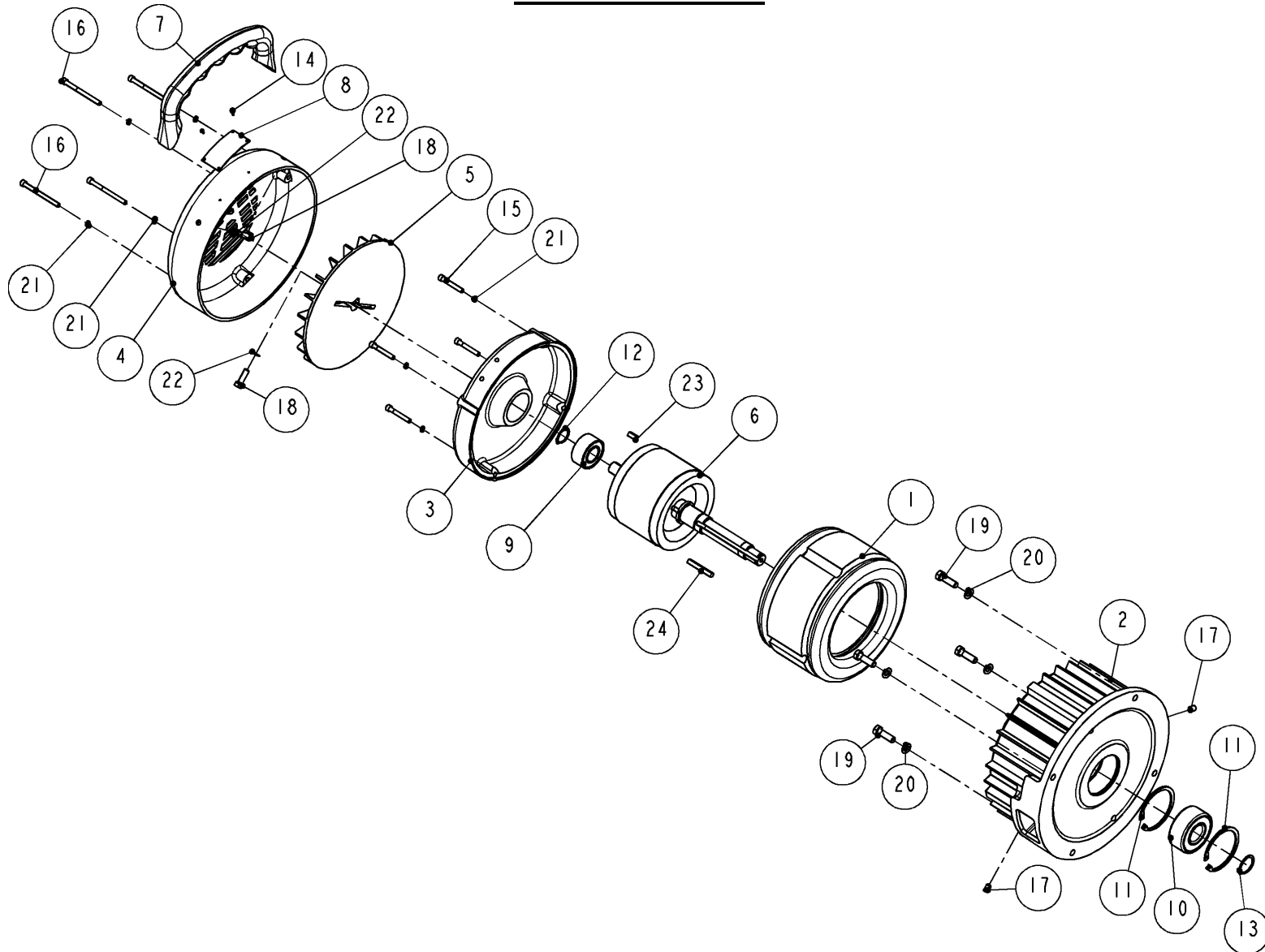

Figure 3 MOTOR ASSEMBLY

KENTMASTER MFG. CO., INC. 1801 SOUTH MOUNTAIN AVE., MONROVIA, CALIFORNIA 91016 UNITED STATES OF AMERICA

☎ TELEPHONE: (626) 359-8888 FAX: (626) 303-5151

MOTOR ASSEMBLY			
ITEM	PART #	DESCRIPTION	QTY
1	OPTIONS	STATOR, SEE CHART BELOW	1
2	1201620	MOTOR HOUSING	1
3	1201630	COVER, MOTOR HOUSING	1
4	1201640	GUARD - FAN	1
5	1201651	FAN ASSEMBLY	1
6	1201671	ROTOR SHAFT ASSEMBLY	1
7	1202370	HANDLE	1
8	2000040	NAME PLATE	1
9	3524050	BEARING	1
10	3532060	BEARING	1
11	5002810	RETAINING RING	2
12	5100980	RETAINING RING	1
13	5101180	RETAINING RING	1
14	8081020	SCREW	2
15	8211140	SCREW	4
16	8211240	SCREW	4
17	8313040	SET SCREW	2
18	8413080	SCREW	2
19	8415100	SCREW	4
20	8506160	WASHER	4
21	8506600	WASHER	8
22	8507150	WASHER	2
23	8605030	KEY	1
24	8605160	KEY	1

MOTOR, 3HP, 42V, 3PH, 50HZ, - 60.0AMPS	1202238	2311680
MOTOR, 3HP, 380V, 3PH, 50HZ - 6.6AMPS	1202237-380-350	2311740
MOTOR, 3HP, 220V, 3PH, 50HZ - 11.4AMPS	1202237-220-350	2311740
MOTOR, 3HP, 416V, 3PH, 50HZ - 6.0AMPS	1202233-416-350	2310600
MOTOR, 3HP, 208V, 3PH, 50HZ - 12.0AMPS	1202233-208-350	2310600
MOTOR, 3HP, 230V, 3PH, 50HZ - 11.0AMPS	1202235-230-350	2311700
MOTOR, 3HP, 115V, 3PH, 50HZ - 22.0AMPS	1202235-115-350	2311700
MOTOR, 3HP, 550V, 3PH, 60HZ - 5.0AMPS	1202234	2310620
MOTOR, 3HP, 416/460V, 3PH, 60HZ - 6.0AMPS	1202233-460-360	2310600
MOTOR, 3HP, 208/230V, 3PH, 60HZ - 12.0AMPS	1202233-230-360	2310600
DESCRIPTION	MOTOR OPTION	STATOR (ITEM 1)
MOTOR ASSEMBLY OPTIONS (STATOR)		

Figure 4 BOM FOR MOTOR ASSEMBLY

1201671: ROTOR SHAFT ASSEMBLY			
ITEM	PART #	DESCRIPTION	QTY
1	1201670	SHAFT	1
2	2315030	ROTOR	1
3	8605160	KEY	1

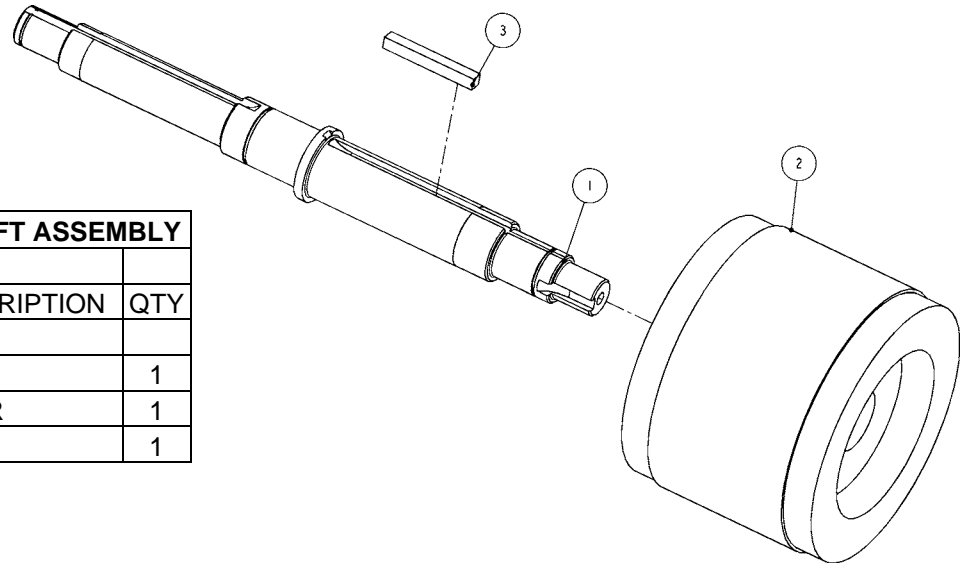
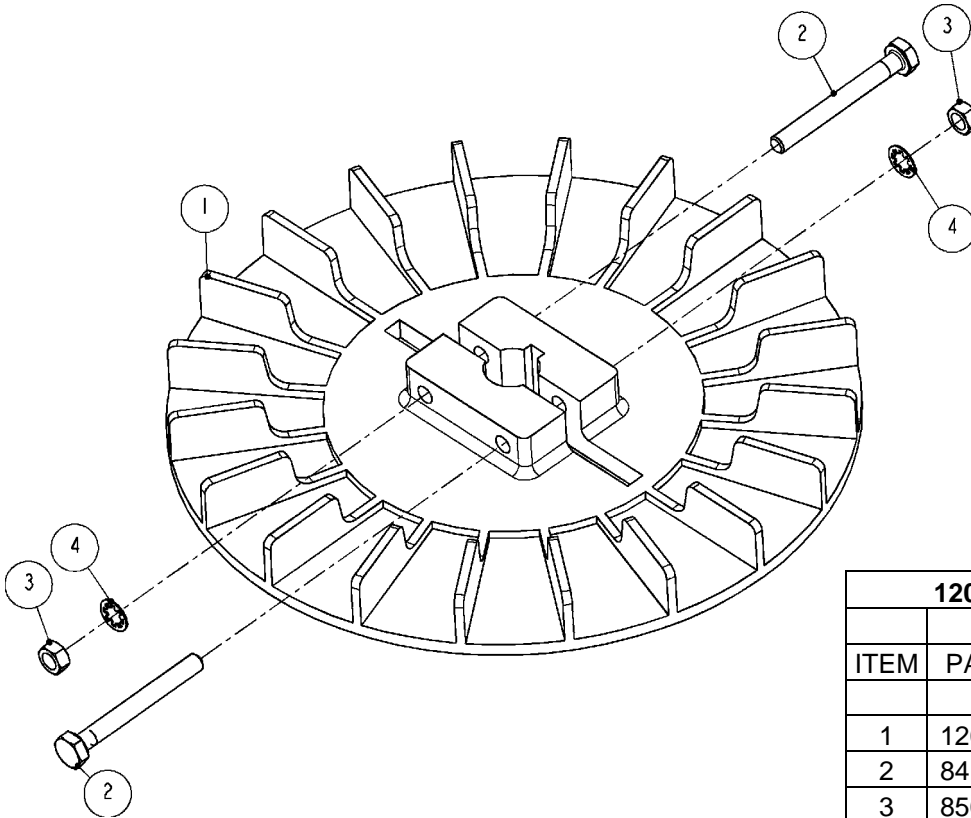

Figure 5 1201671: ROTOR -SHAFT ASSEMBLY



1201651: FAN ASSEMBLY			
ITEM	PART #	DESCRIPTION	QTY
1	1201650	FAN	1
2	8411180	SCREW	2
3	8501410	NUT	2
4	8507100	WASHER	2

Figure 6 1201651: MOTOR FAN ASSEMBLY

POWER SUPPLY

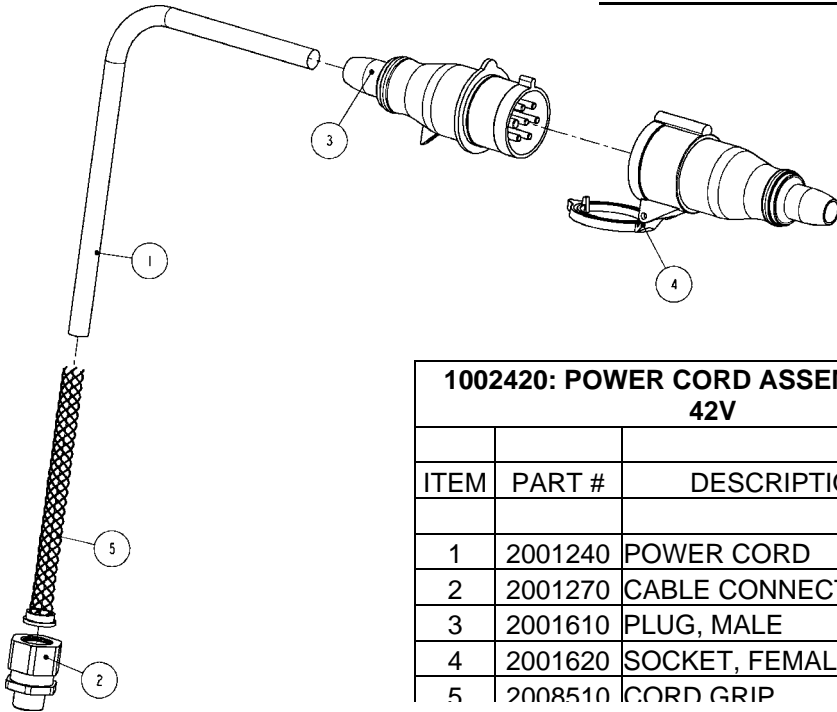

1002420: POWER CORD ASSEMBLY, NON 42V			
ITEM	PART #	DESCRIPTION	QTY
1	2001240	POWER CORD	1
2	2001270	CABLE CONNECTOR	1
3	2001610	PLUG, MALE	1
4	2001620	SOCKET, FEMALE	1
5	2008510	CORD GRIP	1

Figure 7 1002420: POWER SUPPLY, NON 42V

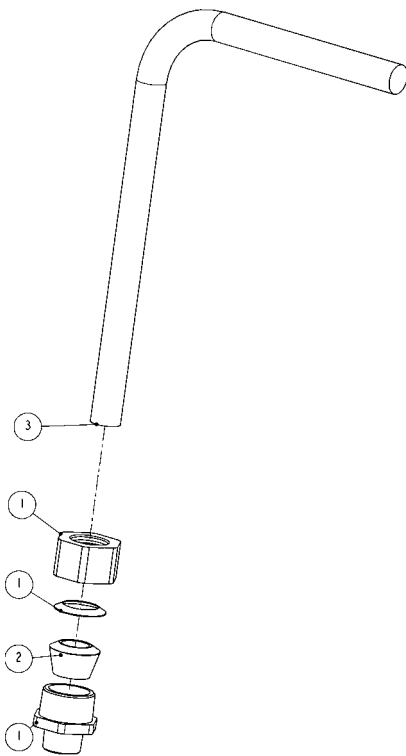

1002430: POWER CORD ASSEMBLY, 42V			
ITEM	PART #	DESCRIPTION	QTY
1	2001270	CABLE CONNECTOR	1
2	2001700	GROMMET	1
3	2007030	POWER CORD	1

Figure 8 1002430: POWER SUPPLY, 42V

SWITCH ASSEMBLY

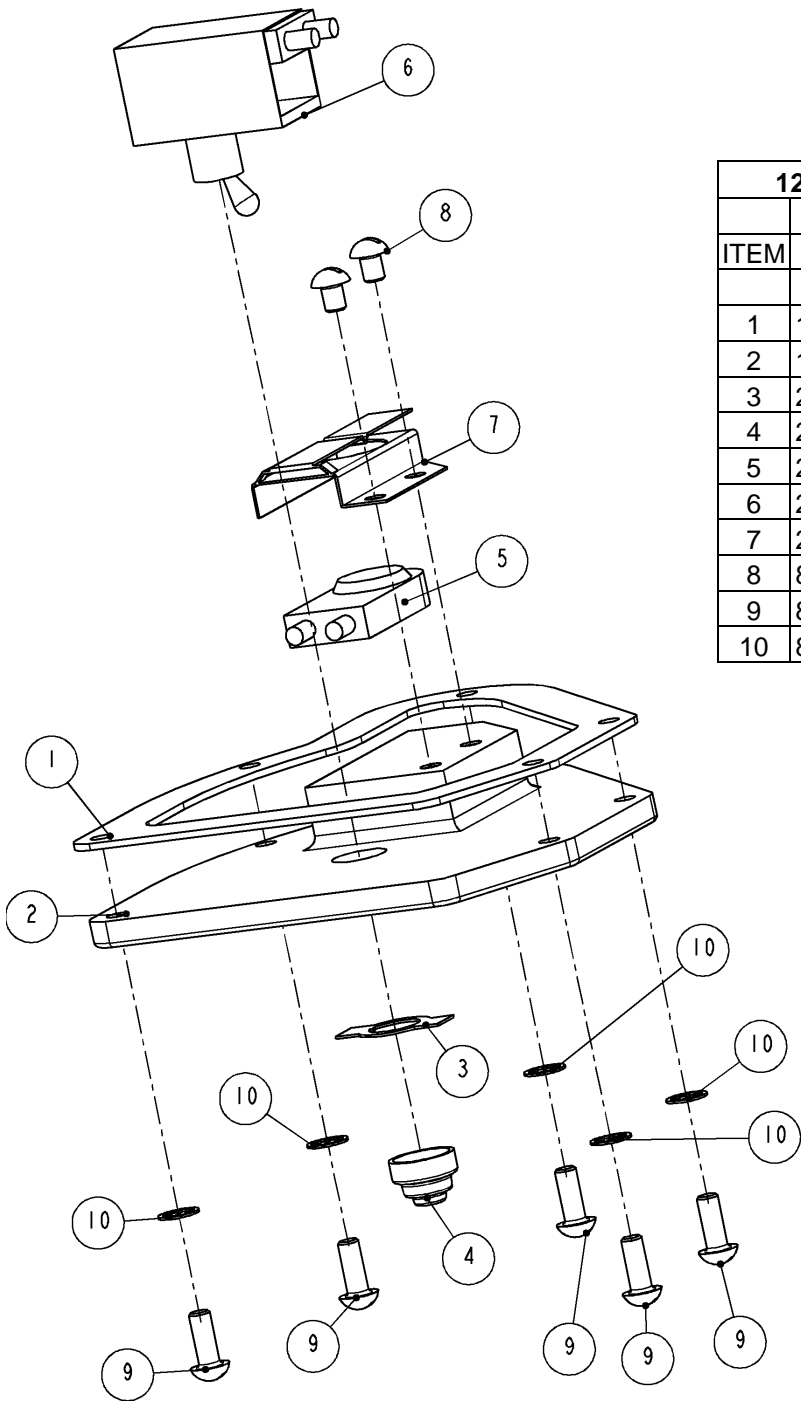

1202540: SWITCH PLATE ASSEMBLY			
ITEM	PART #	DESCRIPTION	QTY
1	1201960	WIRE BOX GASKET	1
2	1202520	WIRE BOX COVER	1
3	2000130	ON-OFF PLATE	1
4	2000140	BOOT, TOGGLE SWITCH	1
5	2000690	SWITCH	1
6	2000730	SWITCH	1
7	2000770	TOP PLATE, SWITCH	1
8	8029020	SCREW	2
9	8029040	SCREW	5
10	8507090	WASHER	5

Figure 9 1202540: SWITCH PLATE ASSEMBLY

FRAME & REAR HANDLE

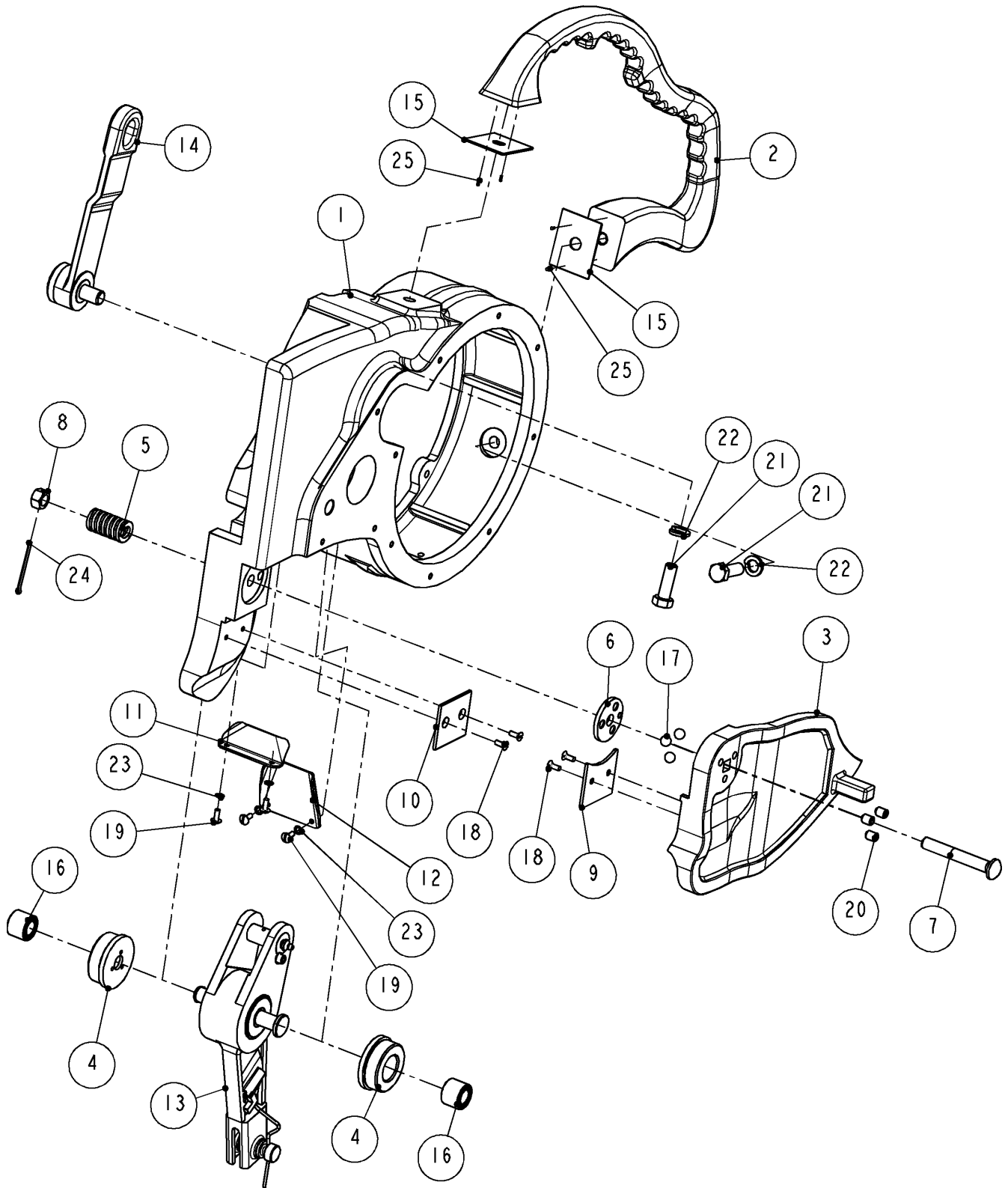
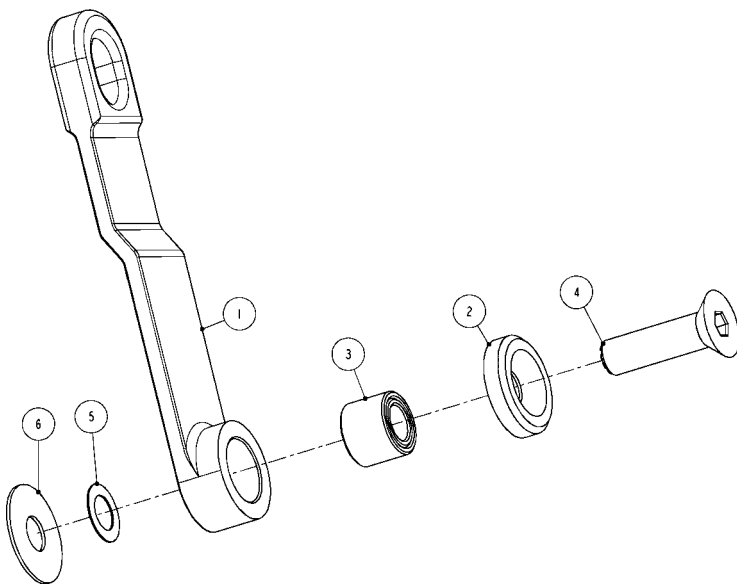

Figure 10 1203001: FRAME AND REAR HANDLE ASSEMBLY

1203001: FRAME AND REAR HANDLE ASSEMBLY			
ITEM	PART #	DESCRIPTION	QTY
1	1200010	FRAME	1
2	1200020	HANDLE	1
3	1200050	SAW GUARD	1
4	1200170	BUSHING	2
5	1200470	SPRING	1
6	1200751	PLATE GUIDE INDEX	1
7	1200910	BLADE GUARD PIVOT BOLT	1
8	1200920	NUT	1
9	1200930	GUIDE PLATE, RH	1
10	1200940	GUIDE PLATE, LH	1
11	1201330	COVER, FRONT	1
12	1201340	COVER, REAR	1
13	1201520	ASSEMBLY, ROCKER ARM	1
14	1202470	HANGER, ASSEMBLY	1
15	1202500	INSULATOR, HANDLE	2
16	1710031	BEARING ASSEMBLY	2
17	6001430	BALL	3
18	8010040	SCREW	4
19	8110040	SCREW	4
20	8345030	SET SCREW	3
21	8418120	SCREW	2
22	8506180	WASHER	2
23	8507090	WASHER	4
24	8631140	PIN	1
25	8640130	DRIVE SCREW	4

Figure 11 BOM FOR FRAME AND REAR HANDLE ASSEMBLY



1202470: HANGER, ASSEMBLY			
ITEM	PART #	DESCRIPTION	QTY
1	1202200	HANGER	1
2	1202210	WASHER, HANGER	1
3	1710032	BEARING ASSEMBLY	1
4	8250180	SCREW	1
5	8705340	SHIM	1
6	8705480	SHIM	1

Figure 12 1202470: HANGER ASSEMBLY

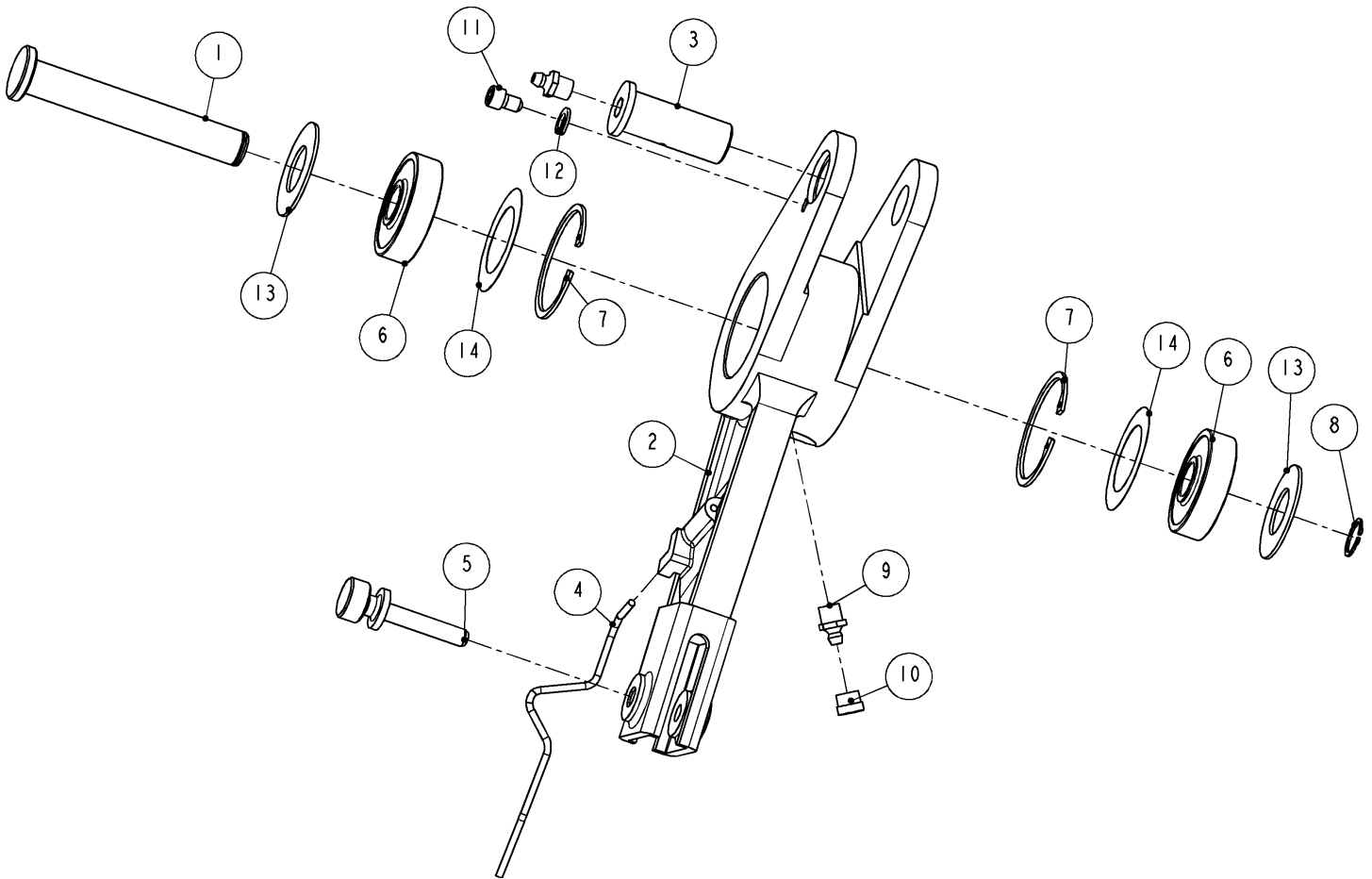

1201520: ASSEMBLY, ROCKER ARM			
ITEM	PART #	DESCRIPTION	QTY
1	1200330	SHAFT	1
2	1201740	ROCKER ARM	1
3	1201820	SHAFT	1
4	1500310	SPRING, BLADE PIN LOCK	1
5	1500320	PIN	1
6	3600200	BEARING	2
7	5001930	RETAINING RING	2
8	5100620	RETAINING RING	1
9	7016100	LUBE FITTING	2
10	7018400	CAP, LUBE FITTING	1
11	8211030	SCREW	1
12	8506100	WASHER	1
13	8705680	WASHER	2
14	8705810	WASHER	2

Figure 13 1201520: ROCKER ARM

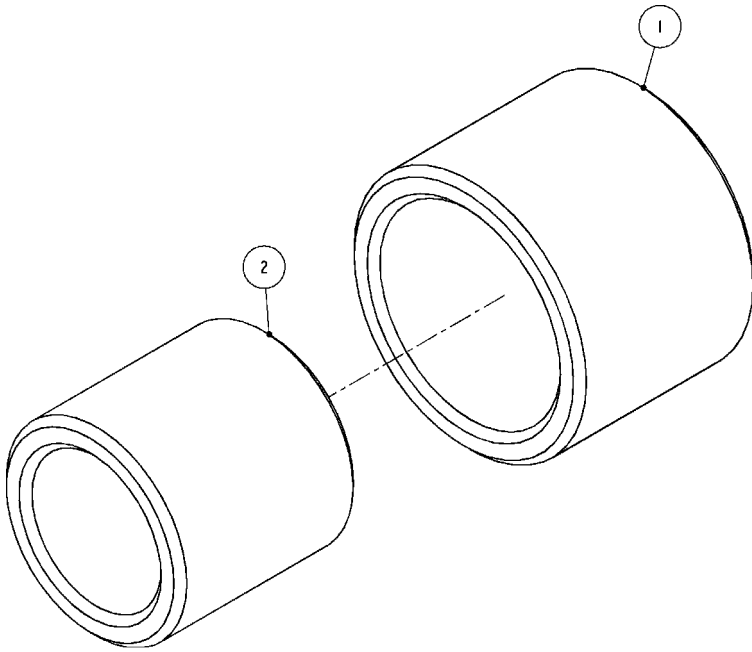
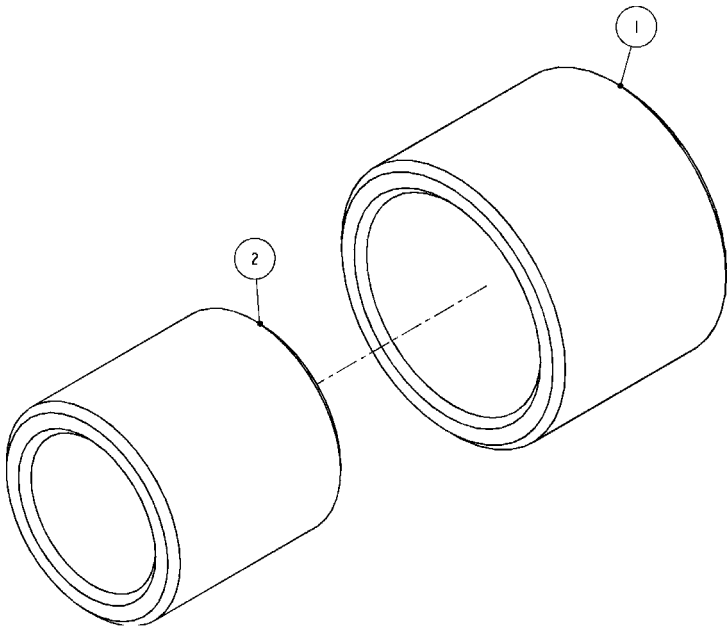

Figure 14 1710031: BEARING ASSEMBLY



1710032: BEARING ASSEMBLY			
ITEM	PART #	DESCRIPTION	QTY
1	1710030	OUTER BEARING	1
2	3706400	INNER BEARING	1

Figure 15 1710032: BEARING ASSEMBLY

YOKE AND SUSPENSION ARM

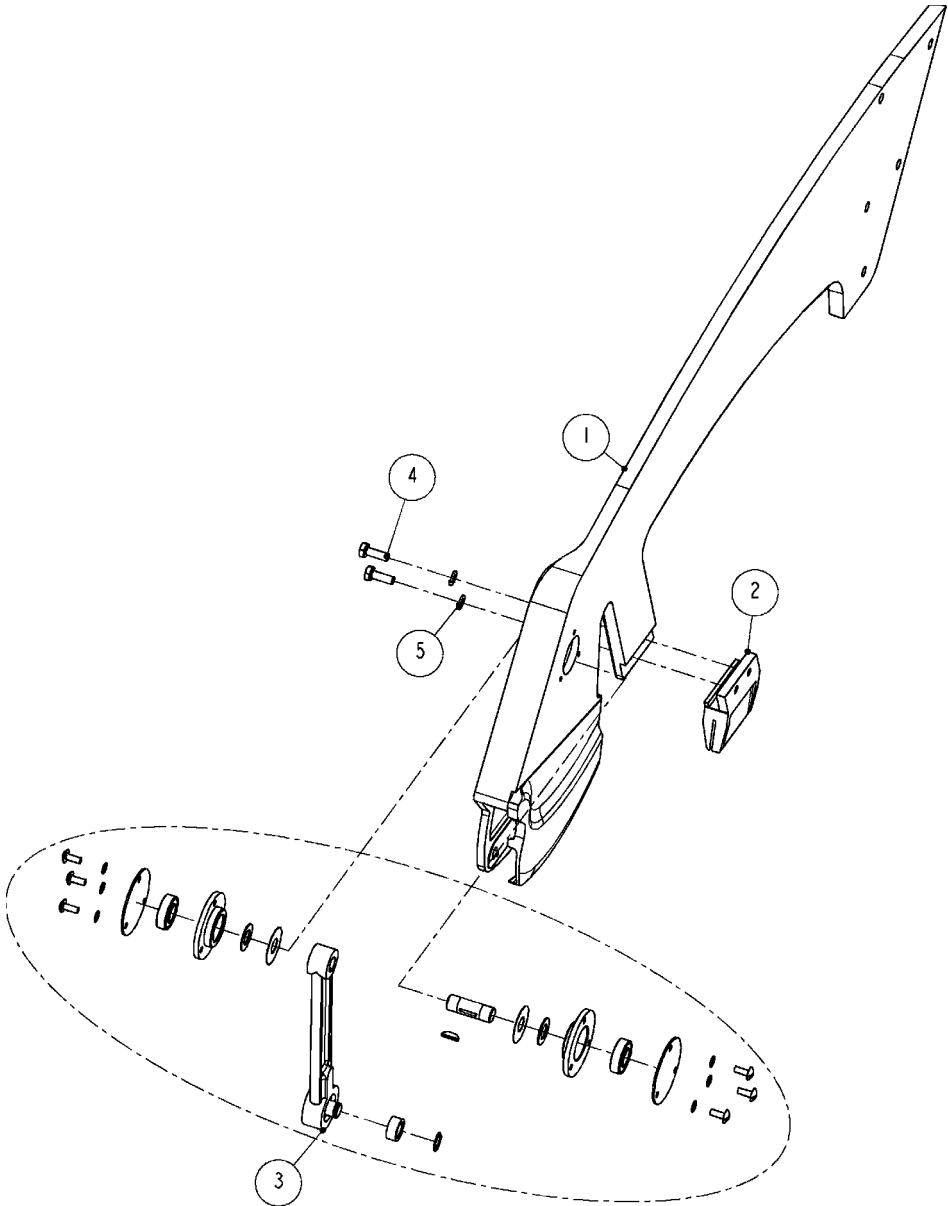

1203002: YOKE AND SUSPENSION ARM			
ITEM	PART #	DESCRIPTION	QTY
1	1201610	YOKE	1
2	1201660	BLADE GUIDE	1
3	1202420	SUSPENSION ARM ASSEMBLY	1
4	8411060	SCREW	2
5	8506100	WASHER	2

Figure 16 1203002: YOKE AND SUSPENSION ARM

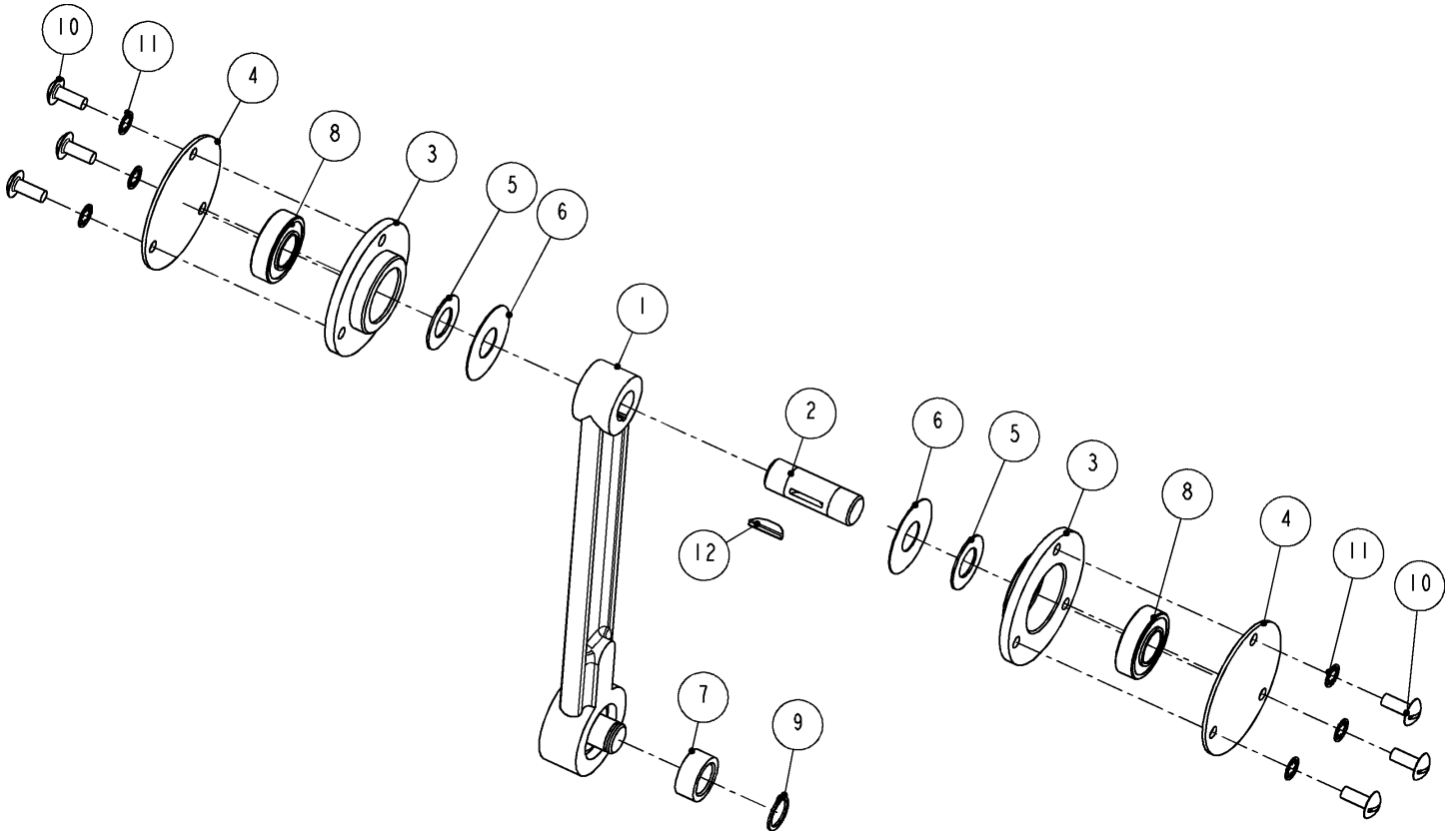

1202420: SUSPENSION ARM ASSEMBLY			
ITEM	PART #	DESCRIPTION	QTY
1	1200230	SUSPENSION ARM	1
2	1200240	SHAFT	1
3	1200260	CARTRIDGE	2
4	1200290	COVER	2
5	1200490	SPACER	2
6	1200500	SPACER	2
7	1500430	BUSHING	1
8	3601180	BEARING	2
9	5100500	RETAINING RING	1
10	8110040	SCREW	6
11	8507090	WASHER	6
12	8600530	KEY	1

Figure 17 1202420: SUSPENSION ARM

WIRING DIAGRAMS

3-PHASE, DIFFERENT CONTROL AND MOTOR VOLTAGE

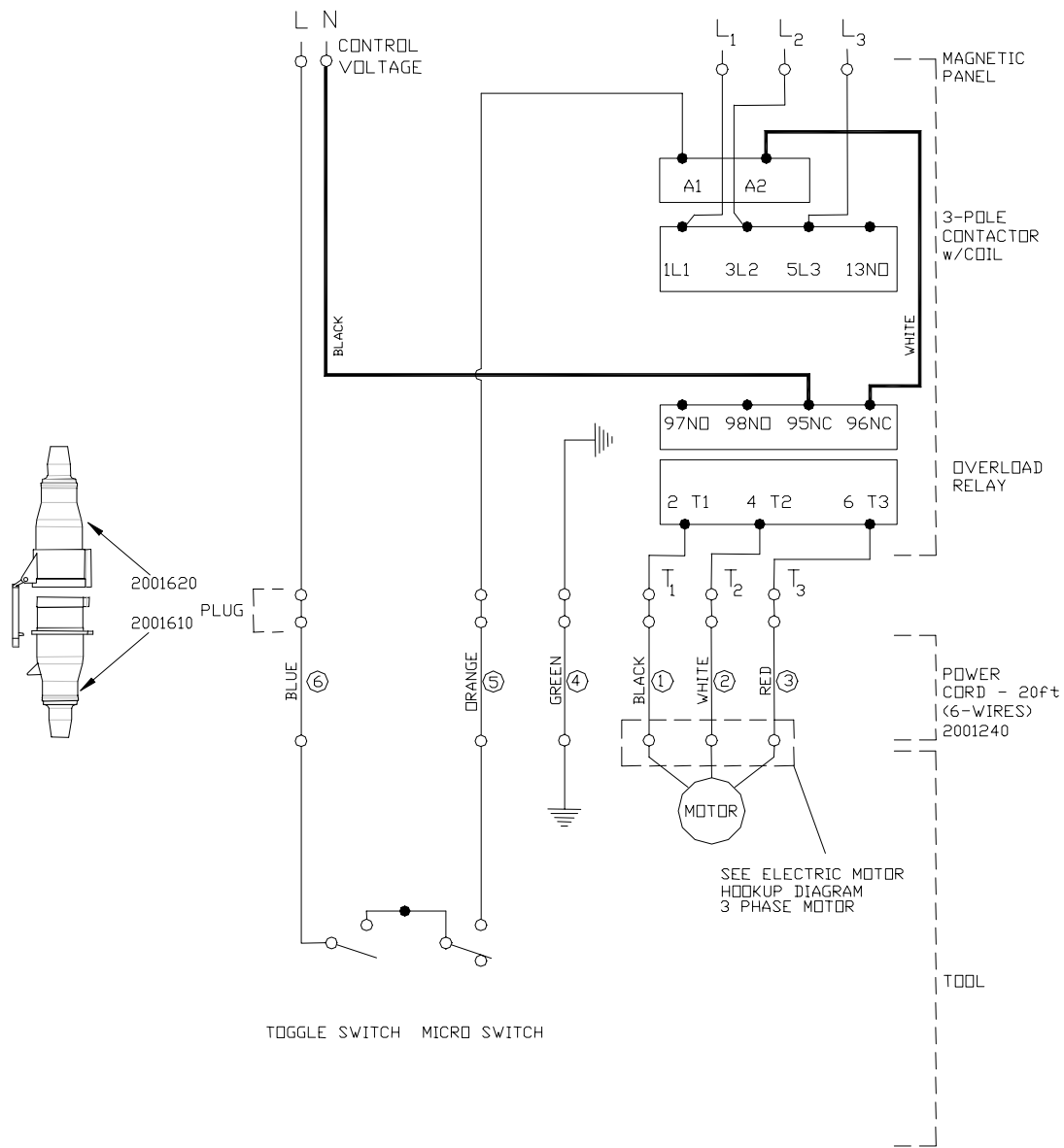

NOTES:

1. DO NOT ATTEMPT OR MAKE REPAIRS ON THE MACHINE WHILE POWER IS ON.
2. ALL ELECTRICAL WORK MUST BE PERFORMED BY A QUALIFIED ELECTRICIAN.
3. THE ELECTRICAL DIAGRAM SHOWS THE MACHINE IN THE "OFF" POSITION.
4. THE GROUND WIRE (GREEN) OF THE POWER CABLE IS CONNECTED TO THE FRAME OF THE MACHINE.

To obtain the correct Kentmaster part number for 3-pole contactor and overload relay, please contact the Kentmaster representative.

Figure 18 WIRING DIAGRAM – different control and motor voltage

3-PHASE, SAME CONTROL AND MOTOR VOLTAGE

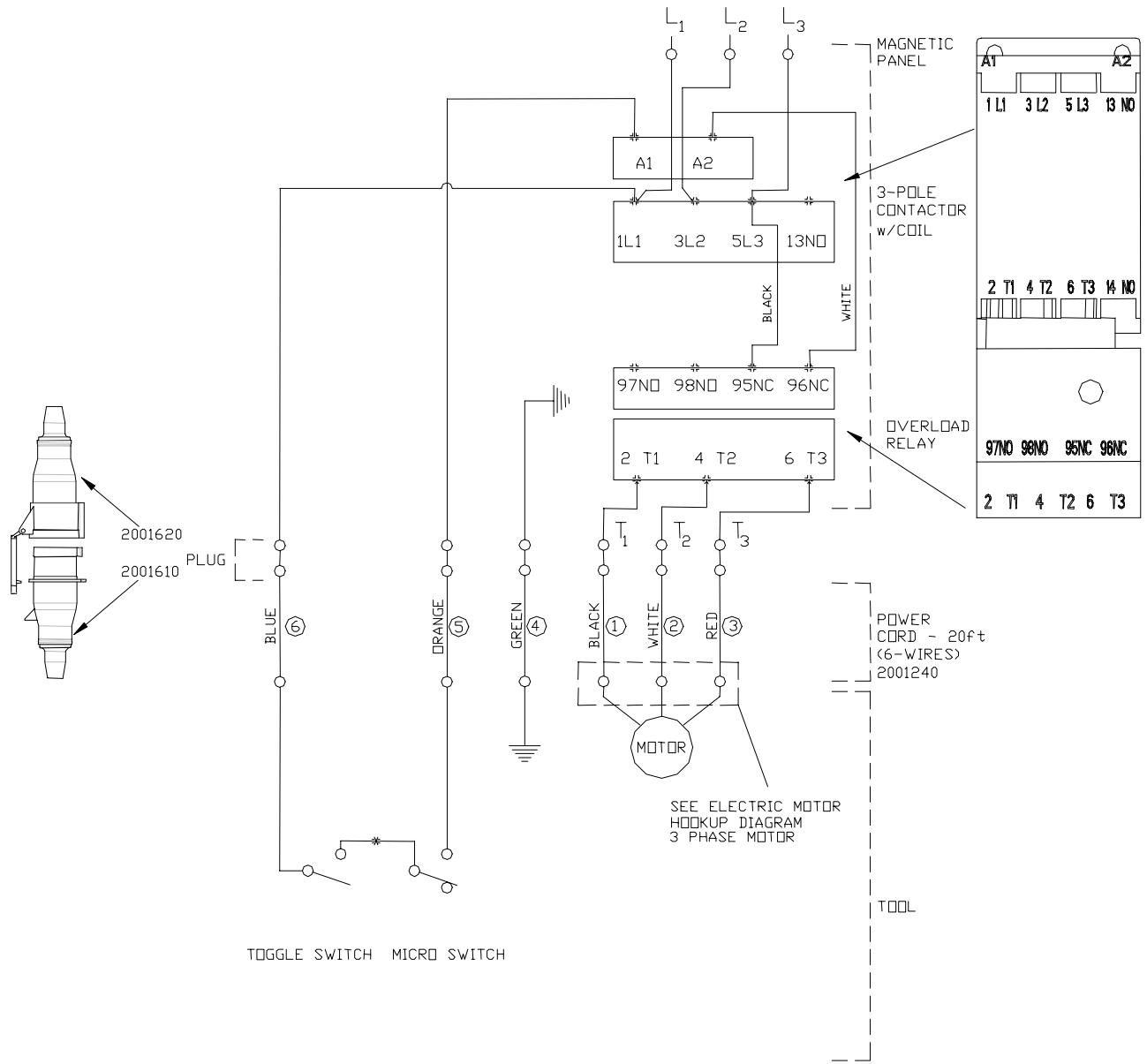

NOTES:

1. DO NOT ATTEMPT OR MAKE REPAIRS ON THE MACHINE WHILE POWER IS ON.
2. ALL ELECTRICAL WORK MUST BE PERFORMED BY A QUALIFIED ELECTRICIAN.
3. THE ELECTRICAL DIAGRAM SHOWS THE MACHINE IN THE "OFF" POSITION.
4. THE GROUND WIRE (GREEN) OF THE POWER CABLE IS CONNECTED TO THE FRAME OF THE MACHINE.

To obtain the correct Kentmaster part number for 3-pole contactor and overload relay, please contact the Kentmaster representative.

Figure 19 WIRING DIAGRAM – SAME control and motor voltage

9 WIRE LEADS, DUAL VOLTAGE STATOR

HIGH VOLTAGE HOOKUP

1,2,3 LINE
 4-7 TIE TOGETHER
 5-8 TIE TOGETHER
 6-9 TIE TOGETHER

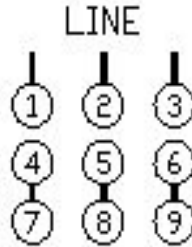

HIGH VOLTAGE

440	460	230	416
220	230	115	208

LOW VOLTAGE HOOKUP

1-7 LINE
 2-8 LINE
 3-9 LINE
 4-5-6 TIE TOGETHER

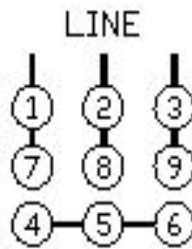

LOW VOLTAGE

6 WIRE LEADS, DUAL VOLTAGE STATOR

HIGH VOLTAGE HOOKUP

1,2,3 LINE
 4-5-6 TIE TOGETHER

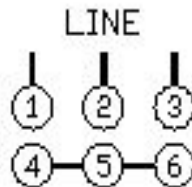

HIGH VOLTAGE

380	416
220	208

LOW VOLTAGE HOOKUP

1-6 LINE
 2-4 LINE
 3-5 LINE

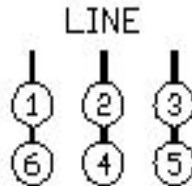

LOW VOLTAGE

3 WIRE LEADS, SINGLE VOLTAGE STATOR

1,2,3 LINE

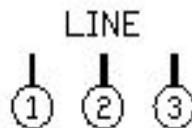

42 VOLTS
 550 VOLTS

Figure 20 ELECTRIC MOTOR LEAD HOOKUP DIAGRAM 3 PHASE MOTOR

[ENGLISH]

GENERAL INFORMATION

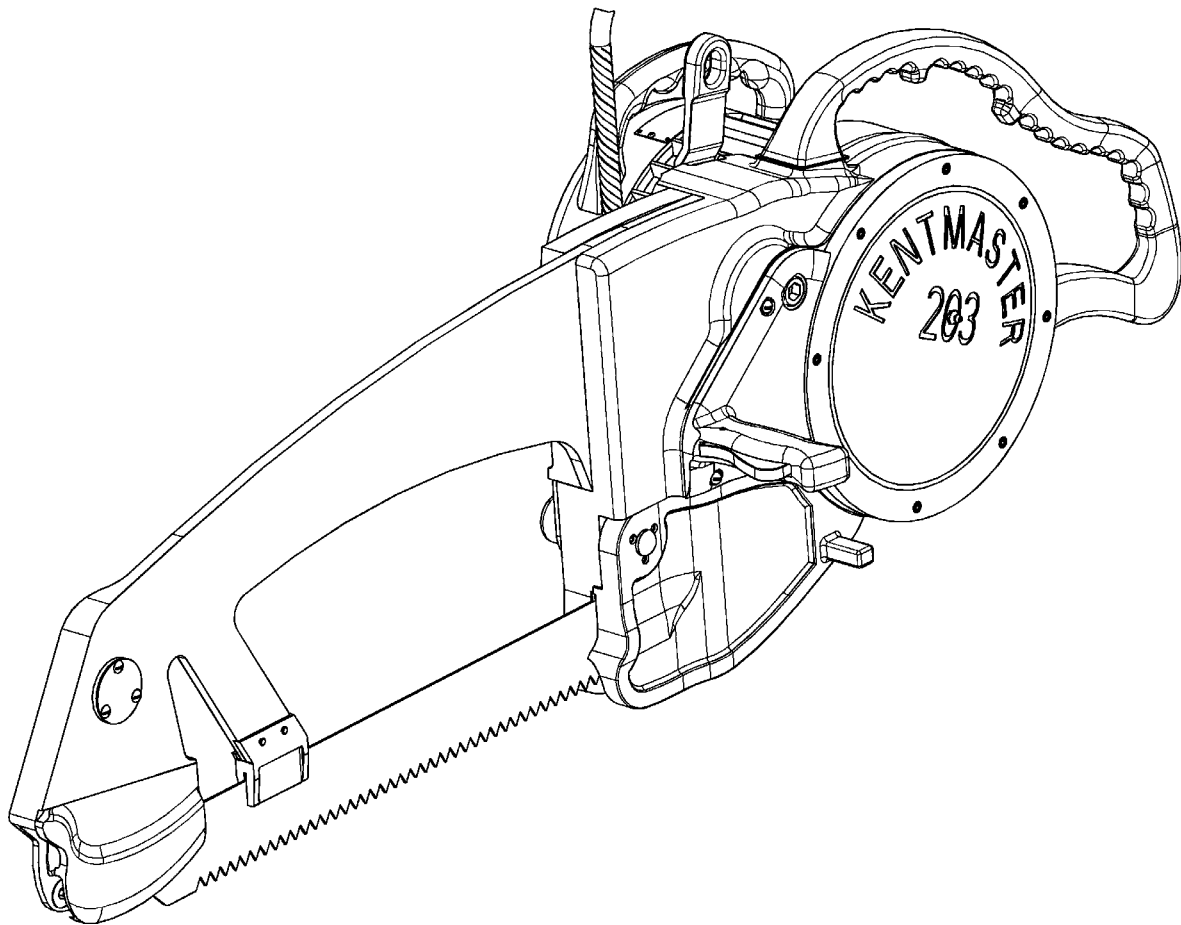

MODEL
“203” BEEF SPLITTING SAW (1200000)

SERVICE CENTERS

KENTMASTER LTD. (U.K)
16 AVONBANK INDUSTRIAL CENTRE
WEST TOWN ROAD
AVONMOUTH - BRISTOL BS11 9DE
UNITED KINGDOM

☎ TELEPHONE: ++ 44- (0) 117- 9235035
FAX: ++ 44- (0) 117- 9829010

KENTMASTER MFG. CO., INC.
1801 SOUTH MOUNTAIN AVE.
MONROVIA, CALIFORNIA 91016
UNITED STATES OF AMERICA

☎ TELEPHONE: (626) 359-8888
FAX: (626) 303-5151

NOTICE TO EMPLOYER AND PURCHASER OF TOOL
NOTICE TO SAFETY DIRECTOR

You have purchased a powerful tool that, if misused, can cause severe injury and harm to your employees. You must instruct your employees in the safe and proper use of this tool and to follow the safety procedures and instructions that have been supplied by the manufacturer of this tool. Please follow the following instructions.

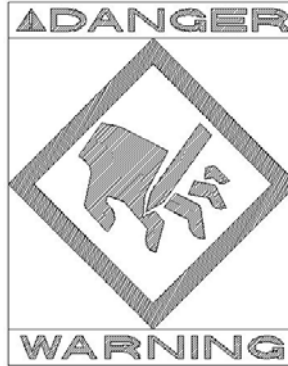

1. Instruct tool operators to test the tool each day before using it to be sure it does not malfunction. Remove and repair any tool that malfunctions.
2. Instruct tool operators to immediately stop using a tool that malfunctions or is defective.
3. Instruct personnel to immediately remove all tools that malfunction. Be sure to disconnect tool from power supply.
4. Instruct all personnel to stay clear of tool, and not to stand or walk in front of, or next to tool when in use.
5. Point out to all personnel the dangers related to the misuse of tool and the importance of following safety procedures and instructions.
6. Do not make, or allow others to make, alterations or modifications to this tool. Replace all lost or illegible labels.
7. Follow all safety, installation and maintenance instructions provided with this tool. Establish proper safety procedures in accordance with local and national requirements to prevent accidental energizing of tool that can cause injuries.
8. If this tool is sold or change in ownership takes place, you must provide the new owner all safety instructions, notices and maintenance instructions you were originally provided. You can obtain additional copies of the instructions from Kentmaster, free of charge upon request.
9. Give copies of instructions to: **(A) Tool Operators**
(B) Maintenance Supervisor
(C) Clean-up Supervisor



GENERAL INFORMATION



COVERING: SAFETY PRECAUTIONS AND PLACING INTO SERVICE
ELECTRICAL POWERED BEEF SPLITTING SAW

READ THIS MANUAL CAREFULLY BEFORE INSTALLING, OPERATING OR SERVICING THIS TOOL

IT IS THE RESPONSIBILITY OF THE EMPLOYER TO PLACE THIS INFORMATION INTO THE HANDS OF THE OPERATOR.

PLACING INTO SERVICE

-  **WARNING** = Hazards or unsafe practices which could result in severe personal injury, death or substantial property damage.
-  **CAUTION** = Hazards or unsafe practices which could result in minor personal injury, product or property damage.
-  **NOTICE** = Important installation, operation or maintenance information.

-  **WARNING** Installation, adjustment repair and maintenance of this tool must be made by trained and qualified personnel.
-  **WARNING** Always disconnect power supply from tool before:
- (A) Installing or removing blade from tool.
 - (B) Making repairs or adjustments to the tool.
 - (C) performing maintenance or cleanup work.

INSTALLATION INSTRUCTIONS

 **WARNING** **ALL ELECTRICAL WIRING MUST BE DONE BY A LICENSED ELECTRICIAN IN ACCORDANCE WITH THE NATIONAL, STATE AND LOCAL ELECTRICAL CODES. (REFER TO NAMEPLATE ON TOOL FOR PROPER POWER CONFIGURATION).**

1. A BALANCER IS REQUIRED FOR OPERATION AND USE OF THIS TOOL. WEIGHT OF TOOL MUST FALL WITHIN WEIGHT RANGE OF BALANCER. "AIR-BALANCERS" WHICH OPERATE ON COMPRESSED AIR, ARE HIGHLY RECOMMENDED FOR USE WITH "203" SAWS. THEY PROVIDE LONG TRAVEL AND VERY SMOOTH, UNIFORM RISE AND FALL. THEY CAN BE INTERFACED WITH THE OPERATION OF THE SAW.
2. INSTALL BALANCER ABOVE WORK AREA. BALANCER MUST HAVE SUFFICIENT VERTICAL TRAVEL SO OPERATOR CAN REACH ENTIRE WORK AREA WITH TOOL WITHOUT STRAIN.
3. ADJUST BALANCER ACCORDING TO THE OPERATOR'S PREFERENCE AND COMFORT.

 **WARNING** **WE STRONGLY SUGGEST THAT AN ADDITIONAL SAFETY CHAIN BE USED TO CHAIN BALANCER TO OVERHEAD TROLLEY. THIS ADDITIONAL MEASURE OF SAFETY WILL HELP REDUCE INJURIES.**

OPERATING INSTRUCTIONS

⚠ WARNING ONLY TRAINED PERSONNEL ARE TO OPERATE THIS TOOL.

WITH THE LEFT HAND FIRMLY ON CONTROL HANDLE, PUSH DOWN ON THE REAR HANDLE WITH YOUR RIGHT HAND AND PLACE SAW IN THE CROTCH OF THE CARCASS. START THE MACHINE AND CUT THROUGH THE TAILBONE. WHILE CUTTING, MOVE YOUR RIGHT HAND FROM THE REAR HANDLE TO THE TOP OF THE MOTOR HANDLE, STANDING DIRECTLY BEHIND THE SAW. AS YOU CONTINUE DOWN THE CARCASS, PUSH THE SAW ALL THE WAY FORWARD AGAINST THE BACK OF THE CARCASS UNTIL YOU HAVE COMPLETED THE CUT.

BY USING THE TRIGGER CONTROL HANDLE WITH YOUR LEFT HAND AND MOTOR HANDLE WITH YOUR RIGHT HAND, YOU CAN MAKE ADJUSTMENTS SO AS TO STAY IN THE CENTER OF THE BACK-BONE BY LIFTING ON ONE SIDE AND PUSHING DOWN ON THE OTHER SIDE. AS THE OPERATOR BECOMES EXPERT WITH THE MACHINE, HE MAY FIND INDIVIDUAL WAYS TO HANDLE THE SAW TO SUIT HIMSELF.

MAINTENANCE

⚠ WARNING ONLY TRAINED AND QUALIFIED PERSONNEL ARE TO PERFORM MAINTENANCE AND SERVICE TO THIS TOOL.

OIL LUBRICATION: THE BACK-FAT OF THE CARCASS PROVIDES SUFFICIENT LUBRICATION FOR THE BLADE GUIDES AND OIL LUBRICATION IS NOT NECESSARY WHEN MACHINE IS IN OPERATION. OIL LUBRICATION SHOULD BE APPLIED AT POINTS A, B, C AND D TO PREVENT OXIDATION AND CORROSION AFTER MACHINE HAS BEEN THOROUGHLY CLEANED AT THE END OF A NORMAL DAYS OPERATION, OR WHEN MACHINE IS NOT TO BE USED FOR AN EXTENDED PERIOD OF TIME.

GREASE LUBRICATION: GREASE LUBRICATION IS RECOMMENDED TWICE WEEKLY AT POINTS E, F AND G. GREASE FITTINGS HAVE BEEN INSTALLED AT THESE THREE POINTS TO SIMPLIFY LUBRICATION. REMOVE 700006 PIPE PLUG TO APPLY GREASE AT POINT E. MANUALLY OSCILLATE 120174 ROCKER ARM UNTIL GREASE FITTING IS IN LINE WITH HOLE ON CONTROL HANDLE, LUBRICATE THIS POINT AND REPLACE 700006 PIPE PLUG. FOR APPLICATION OF GREASE LUBRICANT AT POINT G, GREASE FITTING IS ACCESSIBLE FROM THE MOTOR SIDE OF THE MACHINE. LUBRICATION OF POINTS DESCRIBED ABOVE WILL INSURE PROPER OPERATION AND LONG BEARING LIFE OF YOUR "KENTMASTER 203 BEEF SPLITTING SAW".

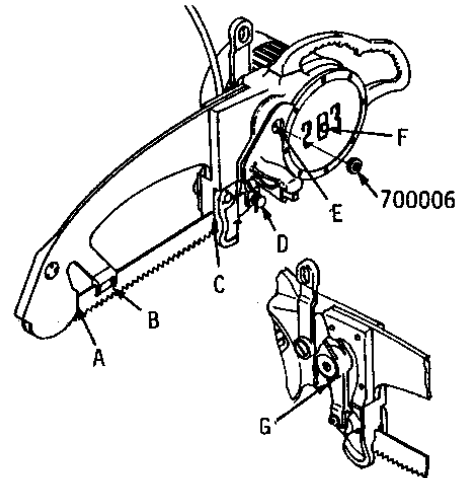

CAUTION: DO NOT OVER GREASE.

RECOMMENDED BEARING GREASE LUBRICANT CAN BE PURCHASED FROM "KENTMASTER MFG., CO., INC."

BLADE REMOVAL AND CLEANING.

⚠ WARNING ALWAYS DISCONNECT POWER SUPPLY FROM TOOL BEFORE INSTALLING OR REMOVING BLADE FROM TOOL.

⚠ WARNING ALWAYS WEAR WIRE MESH GLOVES WHEN INSTALLING OR REMOVING BLADES FROM TOOL.

TO INSTALL SAW BLADE, ROTATE 120005 BLADE GUARD TO THE OPEN POSITION. MOVE 120023 SUSPENSION ARM ALL THE WAY FORWARD AND OUT OF THE NOSE SECTION OF 120264 YOKE ASSEMBLY. MOUNT SAW BLADE ON 150043 ROLLER SUSPENSION ARM, INSERT OPPOSITE END OF SAW BLADE INTO SLOT OF ROCKER ARM AND SAW BLADE. INSERT 150032 BLADE PIN THROUGH BOTH PARTS. PULL BACK ON 150031 SPRING AND SNAP IT INTO THE GROOVE OF 150032 BLADE PIN. TO REMOVE SAW BLADE FROM THE MACHINE, FOLLOW ABOVE PROCEDURE IN REVERSE

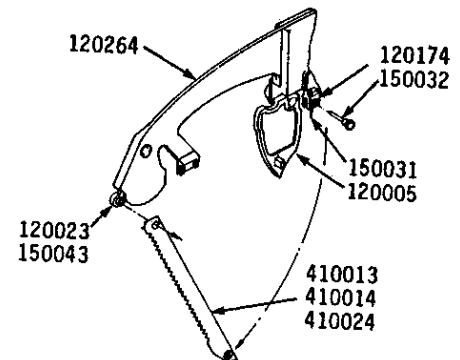

KENTMASTER MFG. CO., INC. 1801 SOUTH MOUNTAIN AVE., MONROVIA, CALIFORNIA 91016 UNITED STATES OF AMERICA

☎ **TELEPHONE:** (818) 359-8888 **FAX:** (818) 303-5151

DECLARATION OF CONFORMITY

DECLARATION OF CONFORMITY

DECLARATION DE CONFORMITE -DECLARACION DE CONFORMIDAD- ERKLARUNG BEZUGLICH EINHALTUNG DER VORSCHRIFTEN
DICHIARAZIONE DI CONFORMITA . CONFORMITEITSVERKLARING

MANUFACTURED BY:

FABRIQUE PAR:
FABRICADA POR:
HERGESTELLTVON:
FABBRICATO DA:
VERVAARDIGD DOOR:

KENTMASTER MFG CO., INC.
1801 SOUTH MOUNTAIN AVE.
MONROVIA, CALIFORNIA 91016
UNITED STATES OF AMERICA
TELEPHONE (626) 359-8888 FAX (626) 303-5151

TYPE / SERIES: BEEF SPLITTING SAW

TYPE / SERIE:
TIPO / SERIE:
TYP / SERIE:
TIPO / SERIE:
TYPE / SERIE:

MODEL: 203

MODELE:
MODELO:
MODELL:
MODELLO:
MODEL:

SERIAL NO. RANGE: XXXXX

N SERIE: • GAMA DE No. DE SERIE: • SERIEN-NR.-BEREICH: • NUMERI DI SERIE: • SERIENNUMMERS:

This product complies with the following European Community Directives:

Ce produit est conforme aux directives de la Communauté européenne suivantes:
Este producto cumple con las siguientes Directrices de la Comunidad Europea:
Dieses Produkt erfüllt die folgenden Vorschriften der Europäischen Gemeinschaft:
Questo prodotto è conforme alle seguenti direttive CEE:
Dit produkt voldoet aan de volgende EG-richtlijnen:

89/392/EEC, 91/368/EEC, 93/44/EEC, 93/68/EEC

The following Standards were used to verify compliance with the Directives:

Les normes suivantes ont été utilisées pour vérifier la conformité avec les Directives:
Las siguientes Normas se usaron para verificar el cumplimiento de las Directrices:
Folgende Normen wurden angewandt, um Erfüllung der Vorschriften zu bestätigen:
Per verificare la conformità del prodotto alle direttive sono stati usati i seguenti standard:
De volgende normen zijn gebruikt om naleving van de richtlijnen te bevestigen:

EN 292

Approved by: _____

Date: AUG - 1 - 1995

RALPH KARUBIAN MONROVIA, CA. U.S.A
(Engineering Manager) (Directeur technique) (gerente de ingeniería) (verantwortlicher Konstruktionsleiter) (Responsabile tecnico) (ondersteunend technisch manager)

Kentmaster Worldwide Location

Kentmaster Equipment (Aust) PTY.LTD.
Unit 2,24 Central Court
Browns Plains Qld. 4118
Australia

Telephone: (07) 3806-8400
Fax: (07) 3806-7933
Australia@Kentmaster.com

Kentmaster do Brasil, Ltda.
Av. Dr. Joao Teodoro No. 805
Bairro De Vila Rezende
13405-240 Piracicaba, SP,
Brazil

Telephone #1: (019) 3 413 3113
Telephone #2: (019)983-4973
Fax: (019) 3 413 3113
Brazil@Kentmaster.com

Kentmaster (IRL) LTD.
Benamore, Dublin Road.
Roscrea,
CO, Tipperary,
Ireland

Telephone: (353) 0505-23292
Fax: (353) 0505-23299
Ireland@Kentmaster.com

Kentmaster Equipment (NZ) LTD.
5 Cooper Street
Havelock North
New Zealand

Telephone #1: (64) 6 8777 857
Telephone #2: 0800 KENTMASTER
Fax: (64) 6 8777 858
NewZealand@Kentmaster.com

Kentmaster South Africa (PTY) LTD.
Johannesburg - S. Africa
Unit 54 Sunnyrock Park
Sunrock Close, Germiston
South Africa

Telephone: (27) 11-455-3748
Fax: (27) 11-455-3749
SouthAfrica@Kentmaster.com

Kentmaster (UK) LTD.
Unit 16 Avonbank Ind. Centre
West Town Rd, Avonmouth-Bristol,
BS11 9DE
England

Telephone: (44) 117-923-5035
Fax: (44)-117-932-9010
UK@Kentmaster.com

Kentmaster Mfg. Co., Inc.
1801 South Mountain Ave.
Monrovia, CA, 91016
USA

Telephone #1: (626) 359-8888
Telephone #2: (800) 421-1477
Fax: (626) 303-5151
info@Kentmaster.com

Kentmaster Omaha
4417 South 139th Street
Omaha, NE, 68137
USA

Telephone #1: (402) 896-3355
Telephone #2: (800) 367-3181
Fax: (402) 896-3311
Omaha@Kentmaster.com

INDEX

<i>OPERATING AND SAFETY INSTRUCTIONS</i>	2
<i>SERVICE</i>	3
<i>PARTS BOOK</i>	3
“203” MAIN ASSEMBLY	3
MOTOR ASSEMBLY	6
POWER SUPPLY	9
SWITCH ASSEMBLY	10
FRAME & REAR HANDLE	11
YOKE AND SUSPENSION ARM	15
WIRING DIAGRAMS	17
3-PHASE, DIFFERENT CONTROL AND MOTOR VOLTAGE	17
3-PHASE, SAME CONTROL AND MOTOR VOLTAGE.....	18
<i>GENERAL INFORMATION</i>	22
INSTALLATION INSTRUCTIONS	22
OPERATING INSTRUCTIONS.....	23
MAINTENANCE.....	23
<i>DECLARATION OF CONFORMITY</i>	24
<i>Kentmaster Worldwide Location</i>	25
<i>INDEX</i>	26
<i>FIGURES - INDEX</i>	27

FIGURES - INDEX

Figure 1 MODEL "203"	4
Figure 2 BOM FOR MODEL "203"	5
Figure 3 MOTOR ASSEMBLY	6
Figure 4 BOM FOR MOTOR ASSEMBLY	7
Figure 5 1201671: ROTOR –SHAFT ASSEMBLY	8
Figure 6 1201651: MOTOR FAN ASSEMBLY	8
Figure 7 1002420: POWER SUPPLY, NON 42V	9
Figure 8 1002430: POWER SUPPLY, 42V	9
Figure 9 1202540: SWITCH PLATE ASSEMBLY	10
Figure 10 1203001: FRAME AND REAR HANDLE ASSEMBLY	11
Figure 11 BOM FOR FRAME AND REAR HANDLE ASSEMBLY.....	12
Figure 12 1202470: HANGER ASSEMBLY	12
Figure 13 1201520: ROCKER ARM.....	13
Figure 14 1710031: BEARING ASSEMBLY	14
Figure 15 1710032: BEARING ASSEMBLY	14
Figure 16 1203002: YOKE AND SUSPENSION ARM.....	15
Figure 17 1202420: SUSPENSION ARM.....	16
Figure 18 WIRING DIAGRAM – different control and motor voltage.....	17
Figure 19 WIRING DIAGRAM – SAME control and motor voltage.....	18
Figure 20 ELECTRIC MOTOR LEAD HOOKUP DIAGRAM 3 PHASE MOTOR	19